



AT-2040 GEN 2

Portable Vibration Calibrator
with Signal Simulator

Operator Manual

Table of Contents

Introduction.....	4	Proximity Probes	53
Product Technical Support.....	4	Installing the Proximity Probe Kit	53
2-Year Limited Warranty.....	4	Connecting the Proximity Probe Driver.....	54
What's New in Gen 2.....	4	Choosing Between a Dynamic and Linear Test	55
Disclaimer.....	5	Conducting a Linear Test	55
Copyright.....	5	Conducting a Dynamic Test.....	57
Safety information	5	MEMS-100 adapter board (optional accessory).....	60
Primary functions	6	Controlling the shaker remotely.....	61
Maximum weight recommendations	6	Controlling the AT-2040 Via VNC Viewer	61
AT-2040 Gen 2 specifications and performance.....	7	Installing and Setting Up the VNC Viewer.....	61
Firmware upgrade instructions.....	8	Controlling the AT-2040 Via TCP Command Protocol.....	63
Instrumentation and control system	8	Overview	63
AT-2040 Physical overview.....	10	Command Structure.....	63
Accessories	12	Command Reference (User-Accessible Commands Only).....	63
Battery operation.....	13	Remote Autotest Step Control.....	66
Operation instructions	14	Additional Remote Engine Control (High-Level GUI-Equivalent Commands)	66
Navigating the AT-2040 User Interface.....	14	Example Automation Sequence.....	67
Using the Capacitive Touchscreen.....	14	Notes and Best Practices	67
Using the Frequency and Amplitude Knobs	15	AT-2040 Remote Command Quick Reference	68
Screen Navigation Tree Structure.....	15	Product maintenance.....	70
Directory Structure	18	Shaker Recalibration	70
Main Menu Screen Overview.....	19	Battery	70
Vibration Output Screen	20	Service Notes	70
Supported Sensor Inputs	20	Operator notes	70
New Features 2025	20	A2LA accreditation.....	71
Vibration Output Screen Overview.....	20	Appendix A.....	72
Performing a Manual Sensor Test.....	22	Test Point Validation	72
PureWave™ Overview	23	Frequency Validation.....	72
Bearing Defect Screen.....	24	Amplitude Validation	72
Bearing Defect Screen Overview	24	Frequency-Dependent Amplitude Limits	72
Conducting a Bearing Defect Test	25	Unit Selection.....	74
Examples	26	Validation Workflow / How Validation Works	75
Sensor Test Screen.....	28	Amplitude and Frequency Changes and Validation	75
Reviewing Automatic Test Data	29	Validation Examples.....	75
Signal Simulation Screen.....	31	Common Scenarios.....	77
Simulation Screen Overview	32	Error Messages Reference	78
Using Simulation Mode.....	32	Field Validation Errors	78
Settings Screen	34	Frequency Change Errors	78
Date & Time Settings Screen	34	Save Errors.....	79
Network Settings Screen	35	Troubleshooting Problems Creating a Custom Sensor	80
Certificate Import/Export Screen	37	Technical Reference	81
Unit Configuration Screen.....	40	Data Storage	81
Unit Info Screen	44	Validation Logic.....	81
Test Setup Screen.....	45	Appendix B.....	83
Reports Screen.....	51	Customizing the PDF Certificate Template.....	83
Calibrating sensors	52	HTML Tags.....	84
Triaxial Sensors	52	HTML Tips.....	84
		HTML Keywords	85

Introduction

This manual is intended to inform the operating user on product specifications, setup, troubleshooting, and operation procedures for the AT-2040 Gen 2 (Rev B Hardware and Rev 2.0 Software). For legacy AT-2040 Gen 1 documentation, refer to Rev A Manual (archived).

This shaker is designed to be a rugged, completely self-contained, battery-powered, vibration sensor test set. The shaker is meant for use in the field or laboratory, for the verification of control room working conditions, or to verify the performance of vibration transducers.

What's New in Gen 2

New in AT-2040 Gen 2:

- Capacitive touchscreen with brighter display.
- Internal LiFePO₄ battery and universal charger.
- Onscreen Automatic Test Setup (no PC needed).
- Real-time sensor type switching and RMS/Peak toggle.
- Enlarged reference platform for improved stability.
- Modernized UI and updated system architecture:
 - Linux kernel provides smoother operation, faster UI rendering, and supports the capacitive display driver.
 - Boot behavior: The system completes kernel boot in \approx 10 seconds, then enters a controlled \approx 30 second hardware stabilization period while the internal audio codec establishes bias references. This ensures consistent amplitude accuracy before operation. Boot time is intentionally unchanged to preserve calibration stability.

Product Technical Support

For technical support for the AT-2040, email us at help@agatetechnology.com or call us at 951-719-1032. Training webinars are also available; contact technical support for more information.

2-Year Limited Warranty

Agate Technology LLC warrants this product against defects in material and workmanship for normal use following published product documentation for a period of TWO (2) years following the date of purchase. The limited warranty includes drift/accuracy. Product documentation includes, but is not limited to, the product manual, datasheet, technical specifications, and communication with our service department. This warranty does not cover damage caused by operator negligence, misuse, abuse, accident, use inconsistent with product documentation, or unauthorized repair or modification by anyone other than Agate Technology and its authorized service providers. Any defective product meeting the above limited warranty requirements will be repaired or replaced at no charge.

Disclaimer

Agate Technology LLC will not be liable for any indirect, special, incidental, or consequential damages, including but not limited to damages for loss of profit or revenue, loss or interruption of business, loss of use, loss of data, or other intangible losses arising from any defect or error in this manual or product.



Although Agate Technology LLC endeavors to produce accurate documentation, this publication may contain inaccuracies or typographical errors. Agate Technology LLC reserves the right to make changes, corrections, and improvements to this manual and product at any time without notice.

Copyright

Copyright © 2026 Agate Technology LLC. All rights reserved. No part of this publication may be reproduced without written permission.

Safety information

Please keep this manual in a safe location for reference.

WARNINGS

- The shaker is designed for vertical use. Operating in the horizontal position is possible as the shaker element has linear bearings for support, but the load should not exceed 400 grams.
- This instrument may shake violently at high amplitude and low frequency. Always make sure to keep the unit secure and operate on a stable surface.
- When amplitude or frequency have exceeded their acceptable ranges, the unit will issue a warning or shutdown, depending on the operating conditions.
- Even when closed, this instrument is not waterproof. Never use near water.
- Failure to hold the accelerometer with the short-handle wrench when attaching and removing transducers can cause permanent damage to the shaker.

Primary functions

- Shake or excite a transducer under test.**
In shake mode, the AT-2040 can be used as a variable frequency and variable amplitude shaker. In this mode, the frequency and amplitude are set manually by the user while the computer provides high-accuracy measurement signals.
- Calculate transducer sensitivity.**
By comparing signals sent to the reference accelerometer by the signal generation board and the signals returned by the transducer under test, the shaker can automatically determine the test transducer's sensitivity to a high level of accuracy.
- Produce a NIST-traceable calibration certificate.**
Once the sensitivity has been calculated and saved across the test transducer's frequency range, the shaker will produce a NIST-traceable certificate and graph in PDF format. This certificate is stored in the computer's memory and may be recalled and exported at any time to a USB memory drive.
- Simulate a transducer using a precision signal (function) generator.**
The shaker is capable of producing signals over a wide amplitude and frequency using its built-in amplifiers to simulate a variety of charge and voltage signals. This allows the user to simulate a working transducer and is the ideal tool for electronics testing, troubleshooting, or calibrating condition monitoring systems.

Maximum weight recommendations

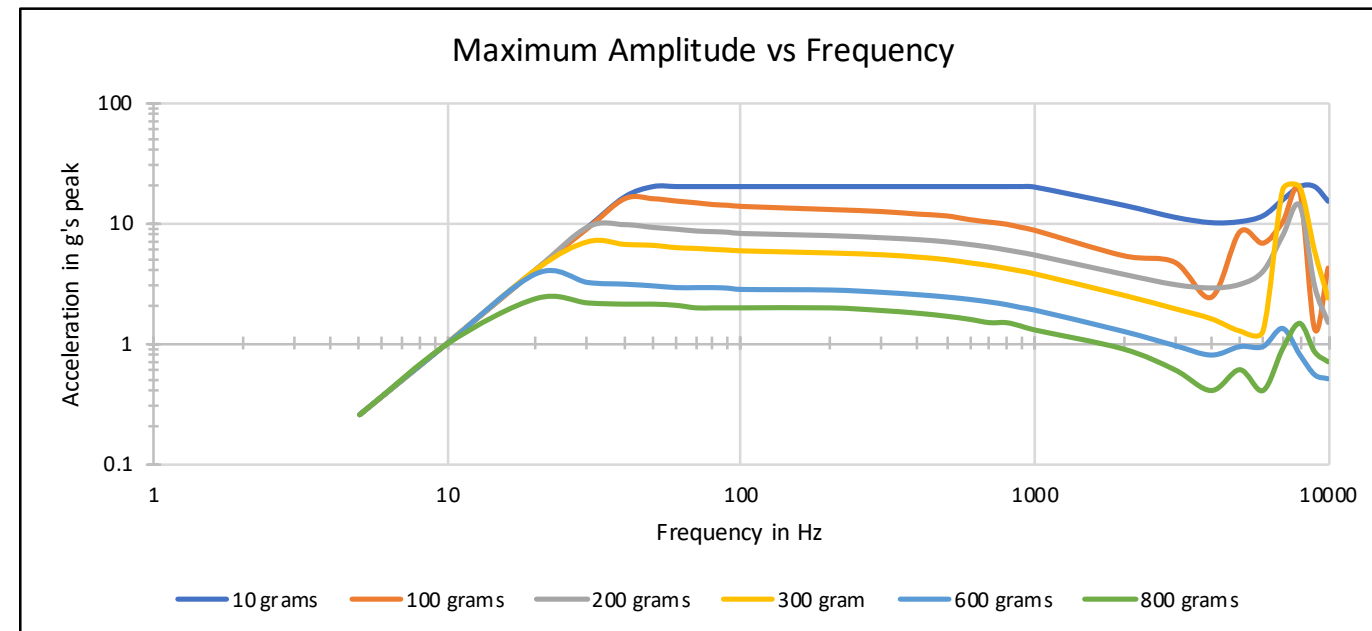

Figure 1 Maximum Weight Recommendations in Grams

AT-2040 Gen 2 specifications and performance

Electrodynamic Shaker Performance		
Frequency Range (operating) ¹	5Hz to 10,000Hz	300 to 600,000RPM
Maximum Amplitude (100 Hz, with no payload)	20 g pk 15 in/s pk 50 mils p-p	196 m/s ² pk 380 mm/s pk 1270 μm p-p
Maximum Payload ²	800 grams	
Waveform Type	Sine or Impulse	
PureWave™ Distortion Correction	<ul style="list-style-type: none"> Active harmonic cancellation system Reduces total harmonic distortion (THD) Corrects up to 30 harmonics 	

System Architecture	
Linux Kernel	OS embedded, optimized for real-time I/O
Database	<ul style="list-style-type: none"> Internal SQL storage for automatic test profiles Create sensor database files on device
Sensor Test Method	<ul style="list-style-type: none"> Manual sensitivity Automatic sweep, with sensitivity and deviation relative to reference frequency. Includes phase data.
Sensor Select	Built-in transducer library
Calibration Sheets	<ul style="list-style-type: none"> Automatic creation to memory Export to PDF or CSV Certificate includes test point with graph
Memory	<ul style="list-style-type: none"> 16 GB (internal storage) MicroSD slot for additional storage
Hardware Architecture	<ul style="list-style-type: none"> FPGA-based signal generation and acquisition 24-bit codec for high-resolution signal processing Digital signal routing for multiple input/output configurations GPIO-controlled relay matrix for signal path selection
Signal Processing	<ul style="list-style-type: none"> DFT-based amplitude and phase measurement Real-time harmonic analysis Configurable high-pass filtering Automatic gain ranging
Safety Features	<ul style="list-style-type: none"> Automatic amplitude limiting based on frequency Over-displacement protection (200 mils p-p maximum) Low-frequency amplitude reduction to prevent mechanical damage Validation of all user-entered test parameters Automatic shutdown on alarm conditions

Simulation Performance ⁴	
Frequency Range	1 to 11,000Hz
Maximum Simulation Amplitude	150g pk @ 10mV/g
Test Type	Manual
Waveform Type	Sine
Simulator Sensor Types Supported	<ul style="list-style-type: none"> Velocity Proximity probes 4-20mA vibration transmitters Accelerometer: Voltage Charge IEPE

Accuracy ⁵	
Acceleration (5Hz to 9Hz)	±3.2%
Acceleration (10Hz to <5kHz)	±2.2%
Acceleration (5kHz to 10kHz)	±3.0%
Velocity (10Hz to 1,000Hz)	±2.2%
Displacement (30Hz to 150Hz)	±2.2%
Amplitude Linearity (100gram payload, 100Hz)	< 1% up to 10g pk
Waveform Distortion (100gram payload, 30Hz to 2kHz)	< 1% THD (typical) up to 5g pk

Input/Output	
Test Sensor Inputs	<ul style="list-style-type: none"> Accelerometer: Voltage Charge IEPE 4-20mA vibration transmitters Velocity MEMS³ Piezoresistive³ Capacitive³ Proximity probes
Bias Measurement	Yes
Sensitivity Measurement	<ul style="list-style-type: none"> Automatic sensitivity calculation in mV/g, pC/g, or mV/unit Phase angle measurement (relative to reference) Distortion percentage display Multi-point frequency sweep capability
Built-in Excitation Current and Supply Voltages for Transducers	<ul style="list-style-type: none"> IEPE current source -24V proximity driver source +24V 4-20mA supply Variable voltage supply

Readout				
Acceleration	g pk	m/s ² pk	g RMS	m/s ² RMS
Velocity	mm/s pk	in/s pk	mm/s RMS	in/s RMS
Displacement (peak to peak)	mm p-p	mm p-p	μm p-p	
Frequency	Hz		RPM	

Bearing Fault Simulator	
Fault Types	Outer Race (BPFO), Inner Race (BPFI), Cage Fault (FTF)
Ball-Count Range	1-99 (user adjustable)
Shaft Speed Range	User adjustable (Hz or RPM)
Amplitude Units	g(Peak)
Fault Signal Components	Impact pulses, BPFO/BPFI/FTF frequencies
Harmonics Generated	2x, 3x, 4x fault frequency (amplitude decreases with order)

Power	
Internal Battery	12V DC
Battery Type	LiFePO ₄
Battery Charge Time	1 hour
Battery Life Expectancy	5,000 cycles at 80% depth-of-discharge, or 10 years
AC Power Input (for recharging battery)	100-240V AC, 50-60Hz, integrated charger with IEC C13 power cord
Operating Battery Life	10 hours (100gram payload, 100Hz 1g pk), 1 hour (100gram payload, 100Hz 10g pk)

Physical	
Sensor Connectors	BNC, DIN, terminal strip
Display	4.3" capacitive TFT LCD (480x272 px), high-brightness, anti-glare surface
Controls	Capacitive touchscreen with 2 dials
Dimensions (H x W x D)	10.6 x 9.7 x 6.9 in / 27 x 24.6 x 17.4 cm
Weight	13.0 lb, 12 oz. / 6.24 kg
Sensor Mounting Platform Thread Size	1/4-28
Operating Temperature	32-122°F / 0-50°C
Agency Requirements and Certifications ⁴	<ul style="list-style-type: none"> A2LA Accredited NIST Traceable EMC:EN61326-1 LVD:EN61010-1 ISO/IEC17025:2017 RoHS ANSI/NCSL Z540 Traceable

Accessories	
Included Accessories	<ul style="list-style-type: none"> Power cable Micro dot (10-32) 1/4-28 stud 2-56 UNC adapter 10-32 UNF stud 6-32 UNC adapter 10-32 UNF adapter Short-handle wrench Universal Accelerometer Adapter Disc Universal Velocity Adapter Disc USB drive, loaded with templates for sensor CSV import and manual
Optional Accessories ⁶	<ul style="list-style-type: none"> Proximity Probe Adapter Kit (digital or manual micrometer) Chadwick-Helmuth® Velocimeter Cable Triaxial Accelerometer Adapter Mems Adapter
Warranty	2 years (includes drift/accuracy)
Tech Support	Training webinars, email support

- 100 gram payload.
- See Figure 1, Maximum Amplitude vs Frequency chart, on page 6 for maximum weight recommendations. Limited at lower frequencies to 0.1 inch (2.54mm) Peak displacement.
- Sensors require a MEMS-100 MEMS Adapter.
- Vibration simulator and bearing fault simulator not part of A2LA scope.
- Accuracy only applies to sine signals; it does not apply to impulse.
- For comprehensive list, please consult the Product Spec Sheet or contact sales.

Firmware upgrade instructions

AT-2040 Gen 2 features software update support to load in sensor information, custom databases, bug fixes, software add-ons, and more. To upgrade to the latest firmware:

1. Plug the included USB flash drive into your laptop or computer.
2. Copy the upgrade file to the USB flash drive.
3. With the shaker powered off, plug the USB flash drive into the shaker. Turn on the shaker.
4. The device will automatically detect the file and prompt you to "Ignore" or "Upgrade". Select **Upgrade**.
5. When the message "Done" is displayed, remove the USB flash drive. The shaker will automatically restart.

⚠ CAUTION: The Gen 2 platform was developed on an updated kernel to support new hardware and features. Do NOT insert Gen 1 software onto a Gen 2 device.

Instrumentation and control system

The shaker consists of an integrated charger, battery, main power amplifier, charge converter, electrodynamic shaker, NIST-traceable reference accelerometer, internal computer, signal generation board, and LCD display screen. See *Figure 2*.

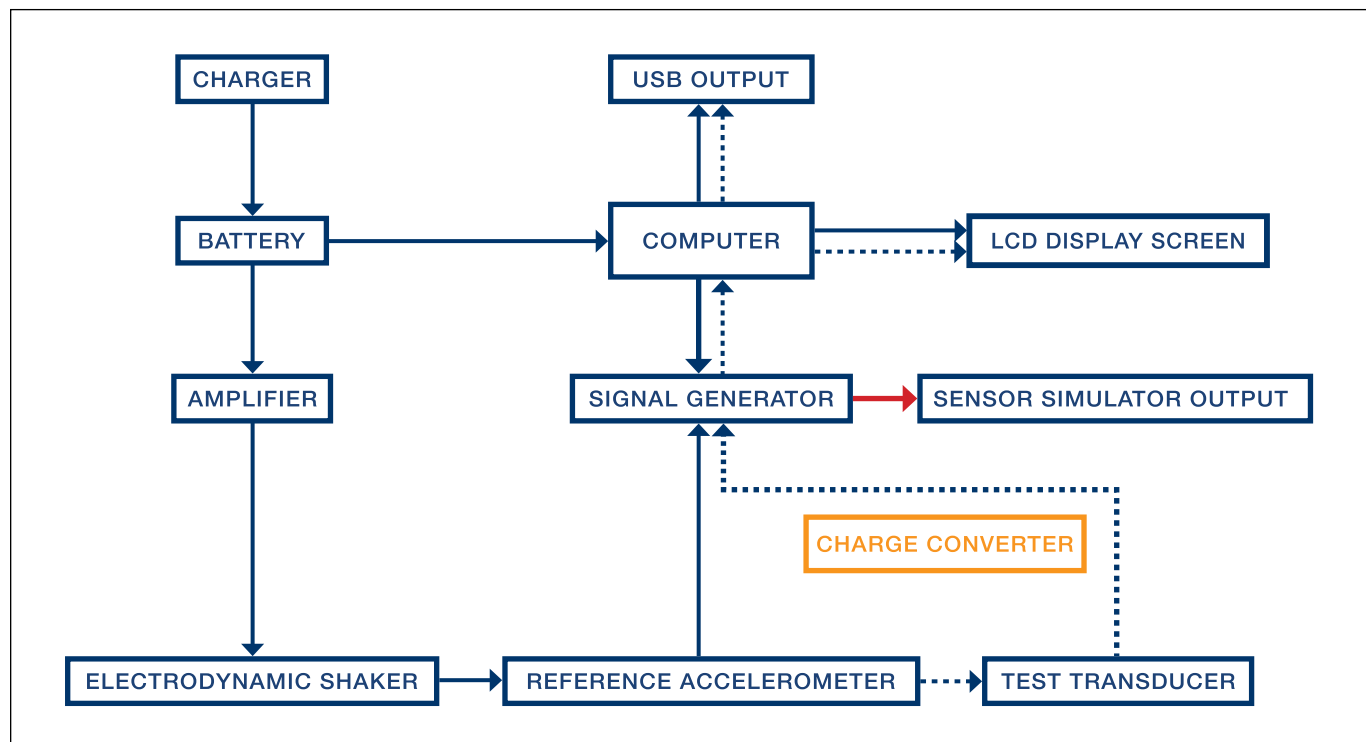

Figure 2

Charger: Integrated charger which operates between 100 V and 240 V AC 50–60 Hz for worldwide power support.

Battery: 12 Volt, 6 amp hour rechargeable LiFePO₄ lithium iron phosphate battery. FAA-transport approved.

Power Amplifier: Takes the input signal from the signal generator and is used to drive the electrodynamic shaker.

Electrodynamic Shaker: Produces 4.5 lbf pk of sine force and is made with carbon-fiber composite and isolated linear bearings. This provides low distortion when shaking the transducer load.

Reference Accelerometer: NIST-traceable calibration standard accelerometer with ¼-28 tapped mounting hole. The reference accelerometer platform has been enlarged and deepened to increase mechanical stability and reduce misalignment during calibration. All existing Agate fixtures remain compatible.

Test Transducer: Calculates sensitivity output.

Signal Generation Board: Consists of multiple amplifiers and channels selectable by internal relays. This is categorized into three different applications:

- **Power Amplifier Output:** Controls the vibration of the electrodynamic shaker at the amplitude and frequency set by the user.
- **Input:** Reads the sensitivity of multiple transducer types.
- **Signal Generator:** Outputs a wide range of simulated voltage and current measurements.

Charge Converter: For direct input of charge mode accelerometers.

Sensor Simulator Output: Generates an artificial transducer signal.

Computer: 1 GHz Cortex-A8 processor, 512 MB DDR3 RAM, 20GB of storage memory included, with USB and network connectivity.

LCD Touchscreen: 4.3" capacitive TFT LCD (480×272 px), high-brightness, anti-glare surface. **NOTE:** The capacitive interface offers improved clarity, responsiveness, and lower power draw compared to the previous resistive screen.

USB Output: Export previous tests to a USB flash drive in PDF or CSV format.

AT-2040 Physical overview

See Figure 3:

- A. **On / Off Button:** Press and hold for 1 second to power on. Press and hold for 5 seconds to power off.
- B. **BNC Sensor Input:** Supports sensitivity testing for charge, IEPE, proximity probes, and velocity sensors.
- C. **Custom Sensor In / Out:** See Rear-View Pinout Diagram (Figure 4) on the next page.
- D. **BNC Sensor Simulator Output:** Simulates a variety of transducer types using adjustable voltage and supply currents through an on-board signal generator. Data provided by the built-in sensor library includes: charge, IEPE, -24 V proximity probe, and 4-20 mA supply.
- E. **Frequency Knob:** Turn the knob to adjust frequency. During screen navigation, turn the knob to move up and down through the onscreen options and press the knob to select.
- F. **Amplitude Knob:** Turn the knob to adjust amplitude. During screen navigation, press the knob to go back.
- G. **LCD Touchscreen:** 4.3" capacitive TFT LCD (480x272 px), high-brightness, anti-glare surface. **NOTE:** The capacitive interface offers improved clarity, responsiveness, and lower power draw compared to the previous resistive screen.
- H. **100-240 V Power Plug Receptacle**
- I. **Dual USB Ports (2):** Plug in peripheral devices, such as a network adapter or a USB memory drive, for importing and exporting files, connecting to a network, and factory calibration. **NOTE:** The shaker must be powered off to load a USB flash drive. If the shaker has problems reading the USB memory drive, restart the device with the USB flash drive plugged in.
- J. **Proximity Probe Driver Input and Power:** Input for radial and axial measurements and built-in -24 V power for the driver.
- K. **4-20 mA Input:** Input for sensitivity test of 4-20 mA transducers and vibration transmitters. Also supplies +24 volt power.
- L. **4-20 mA Sensor Output Simulator:** Capable of providing a test signal between 4 and 20 milliamps.
- M. **Proximity Probe Output Simulator:** Capable of providing a test signal between 0 and -24 volts.
- N. **Electromagnetic Shaker and Reference Accelerometer:** Mounting location for transducer under test (TUT). Always use the short-handle wrench provided; otherwise, twisting force will be applied directly to the electrodynamic shaker.
- O. **Proximity Probe Mounting Locations (2):** The Proximity Probe Adapter Kit, PRX-100, is sold as an add-on accessory.

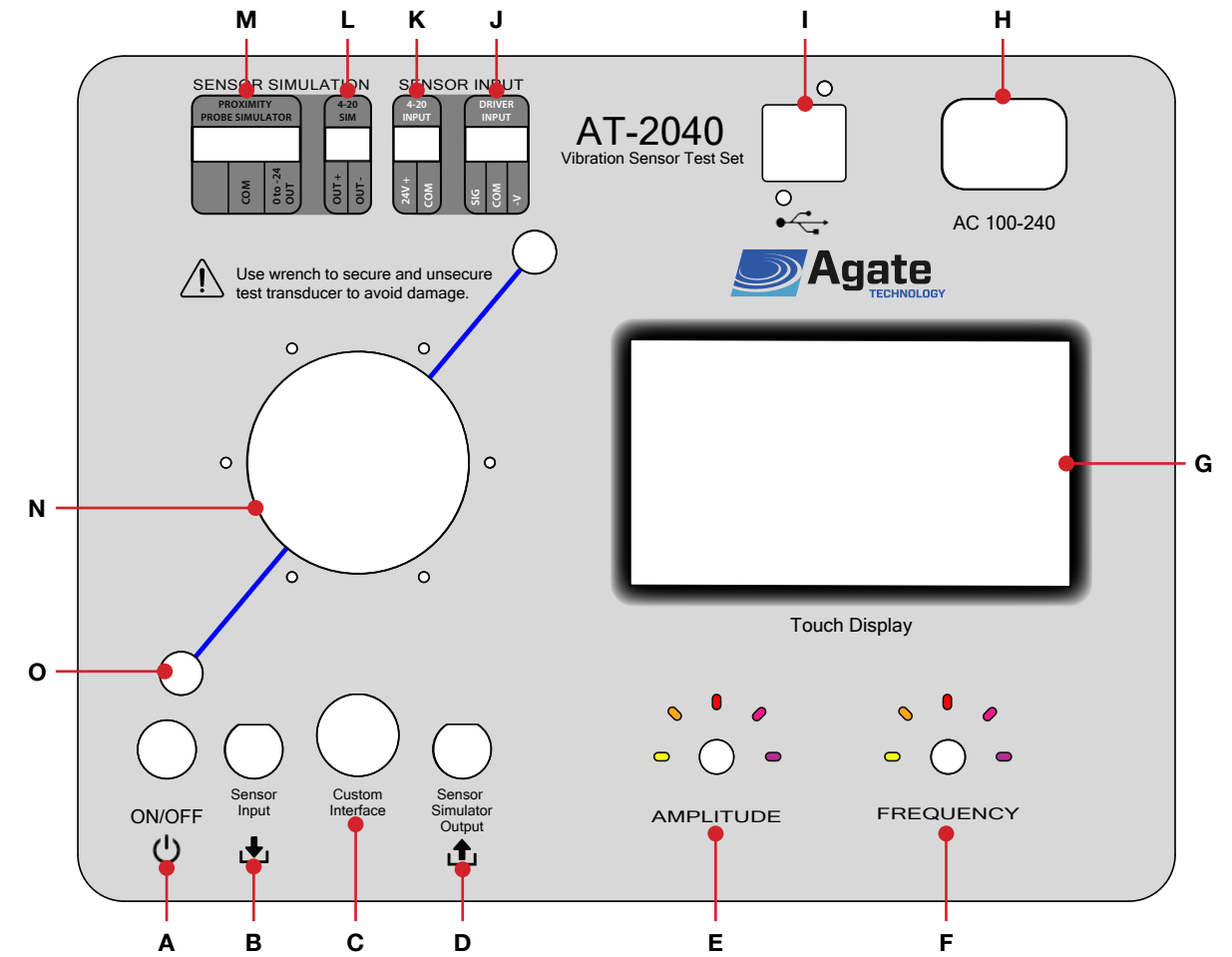

Figure 3

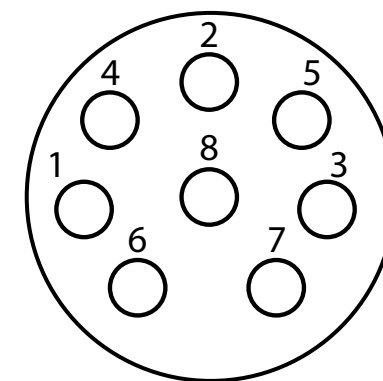

Figure 4 Rear-View Pinout Diagram

- | | |
|---|------------------------------|
| 1. Charge | 5. Channel B: Triax |
| 2. Ground | 6. Channel C: Triax |
| 3. 2-23 Volt Output (Adjustable) | 7. Test Signal |
| 4. Channel A: Input for transducers that provide voltage outputs | 8. Displacement Input |

Accessories

Description	Part No.	Qty
Short-Handle Aluminum Wrench	ACC-100	1
5/32 Hex L-Wrench	ACC-101	1
1/4-28 Stud	MNT-104	1
1/4-28 to 10-32 Stud	MNT-105	1
1/4-28 to 2-56 Adapter	MNT-106	1
1/4-28 to 6-32 Adapter	MNT-107	1
1/4-28 to 10-32 Adapter	MNT-111	1
Universal Velocity Mounting Adapter with 1/4-28 Mounting Hex Screw	MNT-112	1
Universal Accelerometer Mounting Adapter with 1/4-28 Mounting Hex Screw	MNT-113	1
10-32 to BNC Low-Noise Adapter Cable	CAB-101	1
AC Power Cord (120 V or 220–240 V)	PWR-100 or 101	1
3-Position Terminal Block Plug, Female	PL-3-04	1
2-Position Terminal Block Plug, Female	PL-2-05	2
Custom Input DIN Terminal Block Plug, Female	PL-DIN-8M	1
USB Memory Drive	N/A	1

Table 1 Standard Accessories

Description	Part No.	Qty
IEPE Accelerometer 2-Pin Mil to BNC Adapter Cable	CAB-102	1
IEPE Accelerometer 3-Pin Mil to BNC Adapter Cable	CAB-103	1
Chadwick-Helmuth/Honeywell Velocimeter Cable	CAB-107	1
Replacement Studs (3 of each): 1/4-28, 10-32; Adapters: 2-56, 6-32, 10-32	MNT-100	1
1/4-28 Adapter	MNT-108	1
Mounting Stud 1/4-28 to 8-32	MNT-109	1
Adapter 1/4-28M to 3/8-24F	MNT-110	1
Proximity Probe Adapter Kit	PRX-100	1
Proximity Probe Proximity Adapters M6 to 3/8	PRX-101	1
Steel Target (4140)	PRX-102	1

Table 2 Optional Accessories¹

NOTE: All AT-2040 Gen 1 mounting adapters, probe kits, and sensors are compatible with AT-2040 Gen 2.

¹ Custom cables or platform mounts can be made to your specifications based on transducer sample or datasheet. Please contact us for more information.

Battery operation

⚠ WARNING: Only use the supplied IEC C13 power cord to charge. The internal charger is a universal-input and automatically selects the correct voltage.

The AT-2040 Gen 2 is powered by one 6 amp-hour internal LiFePO₄ battery pack providing higher energy density, lighter weight, and extended cycle life. An integrated charger supports 100–240 V AC worldwide input, eliminating external adapters. The battery is designed to be continuously charged at a trickle rate once it reaches 100%. Battery life will depend on USB plug-ins, payload weight, and shaker driving force.

In low-power conditions, the shaker uses approximately 0.4 amps of power making it possible to achieve 13 hours of battery power. However, the shaker will shut down before full discharge to prevent damage and ensure long-term battery life. During long periods of high power consumption, the shaker may only last up to one hour.

A battery LED indicator in the top menu bar turns from green to red as the battery becomes low on energy. An approximate percentage of remaining battery is displayed next to the LED indicator.

NOTES:

- Faster charge rate (typically ≈ 1 hr to 90%).
- The device may operate while charging, but charges fastest when idle.
- No memory effect; safe for partial charge cycles.
- For best results, use the shaker when the battery is fully charged.
- Automatic power management will automatically turn off before full battery discharge. This is a protective measure to ensure longer battery operating life.
- If deep discharge occurs, the battery charger is set to recharge over two or more days. This is normal operation to prevent battery damage.
- The battery lifespan is 5,000 cycles at 80% depth of discharge, or up to 10 years.

LiFePO₄ Batteries vs Lead-Acid Batteries:

- Are safer, compact, lightweight, and have a greater capacity and longer lifespan.
- Can tolerate temperature extremes and rough conditions.
- Are more structurally stable which means that they are much safer; they will not overheat and, even if mishandled or accidentally punctured, they will not explode or catch fire.
- Are also a better choice for the environment as they are non-toxic, do not contain rare earth or toxic metals, and their components—many of which are recyclable—will not leech into the soil or ground water if improperly disposed.

Operation instructions

Powering the shaker on and off:

- Press and hold the red **On/Off button** for 1 second. The shaker will begin its startup sequence.
- Press and hold the red **On/Off button** for 5 seconds to power off. When the screen goes blank, the shaker has powered down.

Navigating the AT-2040 User Interface

The shaker user interface may be navigated using the capacitive touchscreen, the two physical rotary knobs on the panel, or a combination of these two methods.

Using the Capacitive Touchscreen

- Tap a submenu, button, checkbox, or dropdown list to select it.
- Tap the amplitude, frequency, and other adjustable displays on the touchscreen to bring up the number pad and enter the test point value.
- Tap an input field or use the frequency knob to select it. Then, use the onscreen keypad or number pad to enter a value for the parameter.

NOTE: The user interface has a number of toggle buttons that have labels that change depending on their state, for example, the **Start/Stop button**. Before a test begins, the button label reads **Start**; during a test, the label reads **Stop**.

Using the Touchscreen Keypad and Number Pad



Figure 5



Figure 6

- Tap the **Back Arrow key** to delete one character.
- Tap the **Clear key** on the number pad to completely clear the current entry.
- Tap the **OK key** to save and close the keypad or number pad.
- Tap the **Cancel key** on the keypad or the **Exit key** on the number pad to cancel and close the keypad or number pad.

Using the Frequency and Amplitude Knobs

In addition to adjusting the frequency (right knob) and the amplitude (left knob), the two knobs can be used to navigate the onscreen user interface:

1. Turn the **frequency knob** to move up or down through the onscreen options.
2. Press the **frequency knob** to choose the currently selected (highlighted) submenu, button, input field, checkbox, dropdown list, or adjustable display window.
3. Press the **amplitude knob** to go back to the previous screen.

Screen Navigation Tree Structure

- **Main Menu Screen: Select Mode**
- **Vibration Output Button**
 - **Vibration Output Screen**
 - TARGET VIBRATION: value input
 - Peak/RMS toggle
 - RATE: value input
 - Hz/RPM toggle
 - LIVE VIBRATION display
 - SENSITIVITY display
 - Mass Load / Output / Mills / THD indicators
 - Channel: CHARGE button
 - Units: GS button
 - Start button
 - **Bearing Fault Button**
 - **Bearing Defect Screen**
 - TARGET VIBRATION: value input
 - PEAK button
 - RATE: value input (Hz/RPM toggle)
 - FAULT TYPE: selector (OUTER RACE / INNER RACE / CAGE FAULT)
 - BALL COUNT: selector (numeric)
 - Start button
 - **Sensor Test Button**
 - **Manufacturer Select Screen**
 - Scrollable list of manufacturers, for example, ACES, ADASH, and AGATE.
 - **Signal Simulation Button**
 - **IEPE Simulator Screen**
 - TARGET VIBRATION: value input
 - Peak/RMS toggle

- RATE: value input
 - Hz/RPM toggle
- SENSOR TYPE: IEPE Accel
- SENSITIVITY: value input (mV/g)
- BIAS VOLTAGE: value input (V)
- Start button
- **Settings Button**
 - **Settings Menu Screen**
 - **DATE & TIME BUTTON**
 - **Date & Time Settings Screen**
 - TIME (24-Hour Format): Hour/Minute inputs
 - Current System Time display
 - DATE (YYYY-MM-DD): Year/Month/Day inputs
 - Current System Date display
 - TIMEZONE: Region/City selectors
 - SAVE button
 - **NETWORK BUTTON**
 - **Network Settings Screen**
 - CONNECTION STATUS indicator
 - WIFI CONFIGURATION:
 - Network Name (ESSID)
 - Password
 - Security Type
 - IP ADDRESSES:
 - Ethernet IP
 - WiFi IP
 - APPLY SETTINGS button
 - **IMPORT FILE BUTTON**
 - **Certificate Import/Export Screen**
 - USB DEVICE STATUS indicator
 - TEMPLATE FILE info (Filename, Location)
 - ACTIONS:
 - IMPORT FROM USB button
 - EXPORT TO USB button
 - **UNIT CONFIGURATION BUTTON**
 - **Unit Configuration Screen**
 - CONFIGURATION:
 - Company Name
 - Bearing Fault Polarity (+/- toggle)
 - Screen Brightness slider
 - CALIBRATION:
 - CALIBRATE MASS LOAD CORRECTION button
 - **UNIT INFO BUTTON**
 - **Unit Information Screen**
 - Firmware Version
 - Serial Number
 - Calibration Date
 - FPGA Version
 - Battery Type
 - Battery Voltage (with indicator)
 - **TEST SETUP BUTTON**
 - **Test Setup Screen**
 - Manufacturer input
 - Part Number input
 - Sensor Type selector
 - Units selector
 - Amp Mode (Peak/RMS) selector
 - Voltage Out input
 - Current (mA) input
 - Ref Freq (Hz) input
 - Ref Amp input
 - Frequency/Amplitude table (8 rows)
 - Save button
 - **Reports Button**
 - **Test Review Screen**
 - Scrollable list of test reports (showing: Part number, SN, Date)
 - Export buttons: PDF, CSV, ALL

- DELETE button

Directory Structure

screens/

- main_menu.png # Main menu - Select Mode
- VIBRATION OUTPUT/
 - main.png # Vibration Output screen
 - rms_mode.png # RMS mode selected
 - rpm_mode.png # RPM mode selected
- BEARING FAULT/
 - main.png # Bearing Defect - Outer Race
 - inner_race.png # Bearing Defect - Inner Race
 - cage_fault.png # Bearing Defect - Cage Fault
- SENSOR TEST/
 - main.png # Manufacturer Select list
- SIGNAL SIMULATION/
 - main.png # IEPE Simulator screen
- SETTINGS/
 - main.png # Settings menu
 - date_time.png # Date & Time Settings
 - network.png # Network Settings
 - import_file.png # Certificate Import/Export
 - unit_configuration.png # Unit Configuration
 - unit_info.png # Unit Information
 - test_setup.png # Test Setup
- REPORTS/
 - main.png # Test Review list

Main Menu Screen Overview

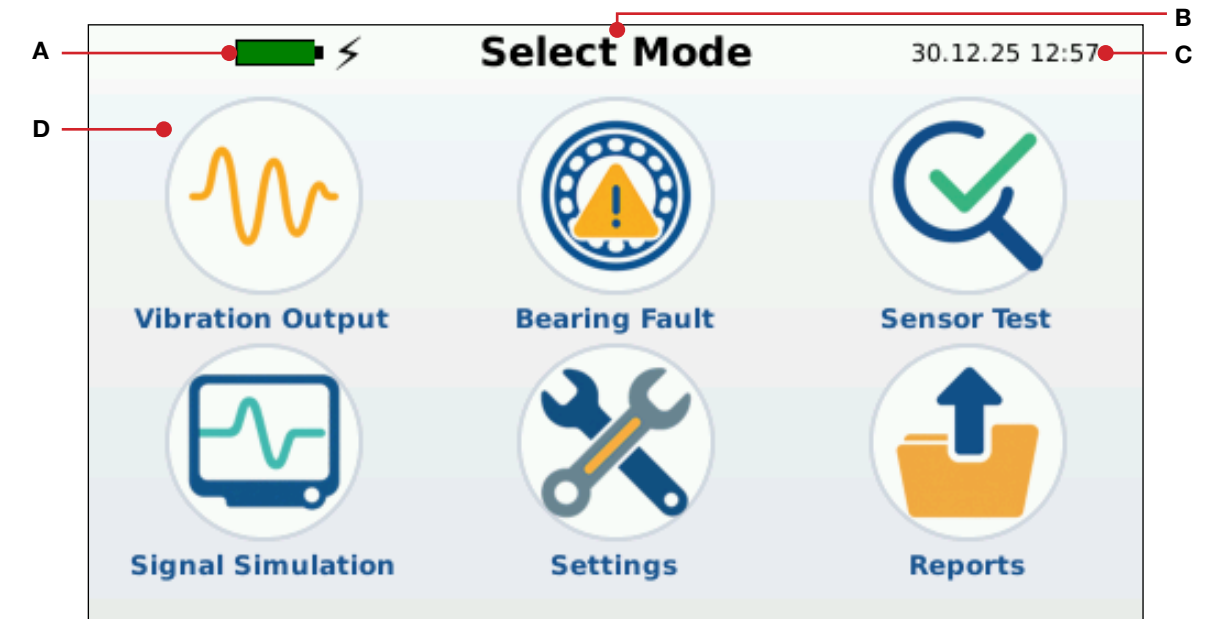

Figure 7

- A. **Battery Indicator:** Shows the remaining battery level.
- B. **Screen Title:** Indicates action(s) to be performed on the current screen.
- C. **Date / Time:** Shows the current date and time.
- D. **Screen/Mode Buttons:**
 1. **Vibration Output:** Select to manually test a specific input channel, or test a transducer or equipment using only variable frequency and amplitude.
 2. **Bearing Fault:** Select to simulate a bearing fault.
 3. **Sensor Test:** Select to test a transducer's sensitivity, using either manual adjustment or automatic plot.
 4. **Signal Simulation:** Select to simulate the signal of a transducer.
 5. **Settings:** Select to customize the shaker options to your preferences.
 6. **Reports:** Select to export test reports to PDF or CSV or to delete reports.

Vibration Output Screen

On the vibration output screen, the operator can manually test a specific input channel to calculate transducer sensitivity. The manual sensitivity test compares known accurate signals sent by the internal signal generator board and the signals received by the transducer under test. The vibration output screen can be used to set up a new system, verify an existing system, or troubleshoot an alarm. For automatic sensor testing, see **Sensor Test Screen** on page 28.

In No Input mode, a transducer or equipment can be tested using only variable frequency and amplitude control. The frequency and amplitude are set manually by the operator, while the computer provides high-accuracy measurement signals.

Supported Sensor Inputs

The shaker uses internal-switching relays to change between channels. All sensor support systems are built into the unit, including a charge amplifier. Sensitivity inputs for the following sensor types are supported: IEPE, Charge, Voltage, 4–20 mA, and Proximity Probe.

New Features 2025

- Toggle between RMS and Peak onscreen in real time.
- Input channels dynamically selectable: IEPE, Charge, Proximity Probe, Voltage, or 4–20 mA.
- Optional No Input mode for shaker-only operation.
- Sensor sensitivity data is now available onscreen.

Vibration Output Screen Overview

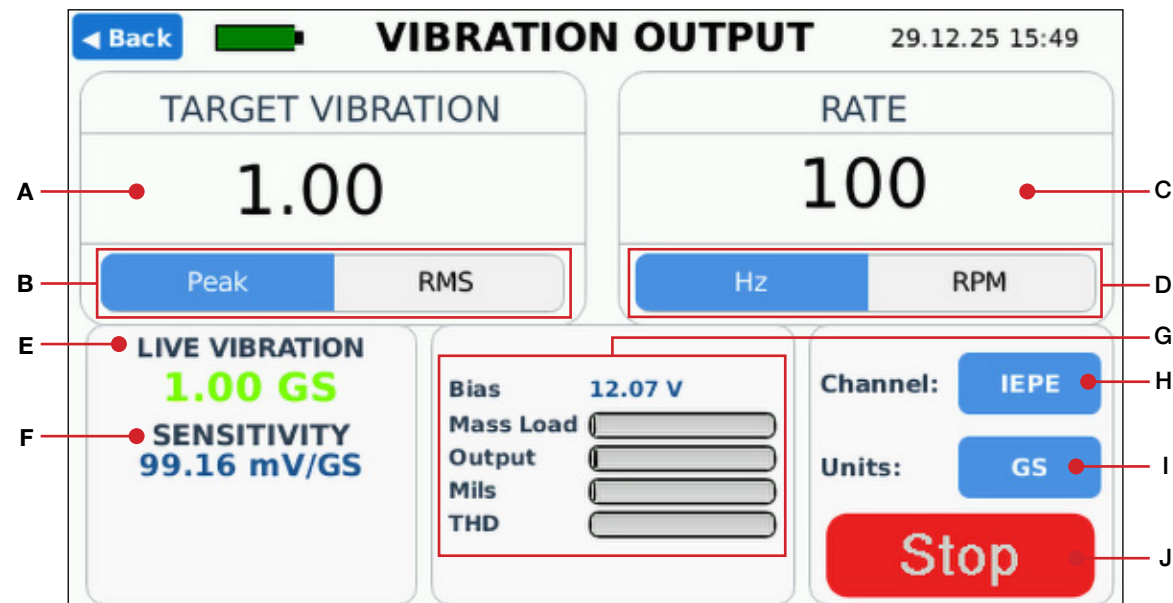

Figure 8

- A. **Target Vibration Input/Display:** Shows the amplitude of the selected input channel. When no input channel is selected, turn the amplitude knob to adjust, or tap the touchscreen display to bring up the number pad and enter the amplitude test point.

- B. **Peak and RMS Toggles:** Tap the toggles to switch between vibration units.
- C. **Rate Input/Display:** Shows the frequency or speed for the selected input channel. When no input channel is selected, turn the frequency knob to adjust, or tap the touchscreen display to bring up the number pad and enter the frequency or RPM test point.
- D. **Hz and RPM Toggles:** Tap the toggles to switch between frequency and RPM.
- E. **Live Vibration Display:** Shows the actual vibration output of the shaker in the selected units.
- F. **Sensitivity Display:** Shows the measured sensitivity of the test sensor.
- G. **Shaker Output Display:**
- **Bias / Gap V:** Bias voltage is shown when an IEPE sensor is selected, and gap voltage is displayed when a proximity probe is selected.
 - **Mass Load Indicator:** Automatic mass payload calculation. The shaker uses this value to automatically calculate mass loading correction.
 - **Output Indicator:** Percentage of amplifier output capability.
 - **Mils Indicator:** Displacement of the electromagnetic shaker in mils.
 - **THD Indicator:** Total harmonic distortion.
- H. **Channel Button:** Tap the button to select an input channel: None (No Input mode), IEPE, Charge, Voltage, Prox, or 4–20mA.
- I. **Units Button:** Tap the button to select the units for the Live Vibration display: GS, MSS, IPS, MMS, MILS, MM, or UM. See *Table 3 Units by Sensor Category*.
- J. **Start/Stop Button:** Tap the onscreen button or use the frequency knob to select the button to start or stop the test.

Category	Description	Available Vibration Units
None (No Input mode)	Shaker-only operation (no sensor selected). Displays vibration output only.	GS, MSS, IPS, MMS, Mils, MM, μM
IEPE Accelerometer	Measures acceleration.	GS, MSS, IPS, MMS, Mils, MM, μM
Charge Accelerometer	Measures acceleration (charge output).	GS
Voltage Accelerometer (DC/AC, MEMS)	Measures acceleration (voltage output).	GS
Velocity Sensor (Piezo / Moving-Coil)	Measures velocity.	IPS, MMS
Proximity Probe	Measures displacement.	Mils, MM, μM

Table 3 Units by Sensor Category

Performing a Manual Sensor Test

1. From the main menu screen, select **Vibration Output** to open the Vibration Output screen ().
2. Select your sensor and mount it to the ¼-28 drill hole in the reference accelerometer.
 - a. Hold the reference accelerometer with the provided short-handle wrench and screw in the sensor at the same time.
 - b. When necessary, use the correct sensor adapter for your size.
3. Select the **Channel button** to choose the input channel (Figure 9):
 - a. Select the transducer type: None, IEPE, Charge, Voltage, Prox, or 4–20mA.
 - b. Select **None** (no input mode) for shaker-only operation.

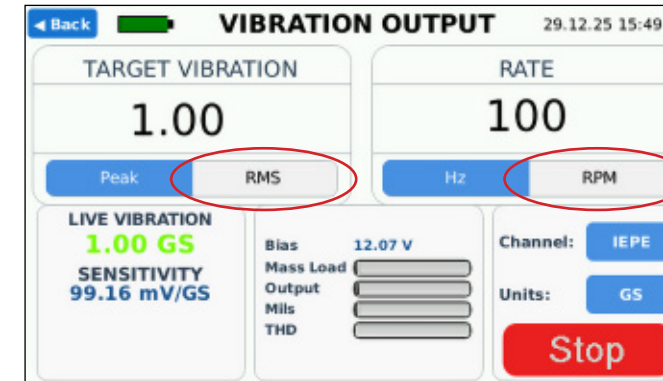
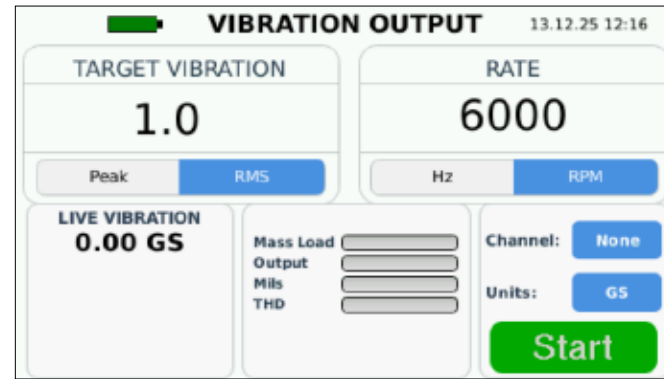

Figure 11

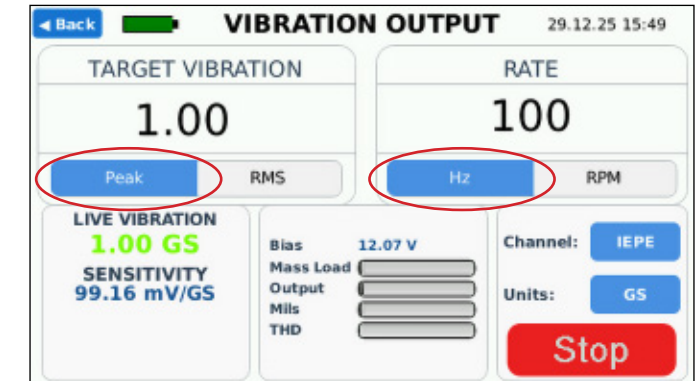

Figure 12

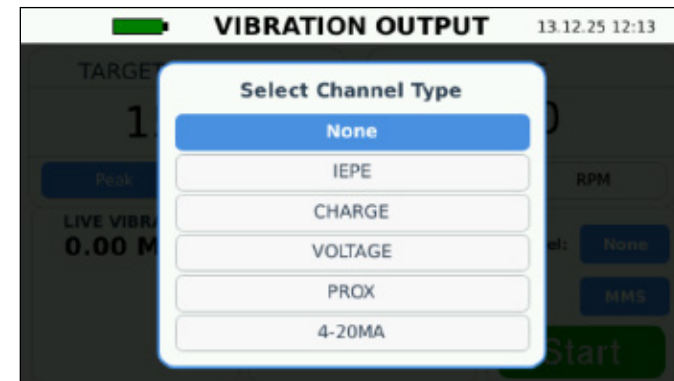

Figure 9

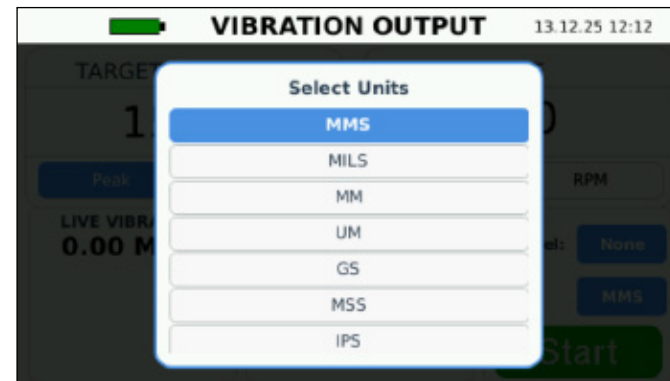

Figure 10

4. Select the **Units button** to set the vibration units to GS, MSS, IPS, MMS, MILS, MM, or UM (Figure 10). The vibration units will be shown for both the live vibration and sensitivity (if the channel is selected).
5. Select the **Start button** to begin the test ().
6. At any point during the test, the operator may:
 - a. Adjust the amplitude:
 - i. Turn the amplitude knob, **OR**
 - ii. Tap the amplitude display on the touchscreen to bring up the number pad and enter the amplitude.
 - b. Adjust the frequency:
 - i. Turn the frequency knob, **OR**
 - ii. Tap the frequency/RPM display on the touchscreen to bring up the number pad and enter the frequency or RPM.
 - c. Adjust the units shown onscreen as needed (Figure 11 and Figure 12):
 - i. Select the **Peak** or **RMS toggle** to switch the vibration units.
 - ii. Select the **Hz** or **RPM toggle** to switch between frequency and speed.

7. Select the **Stop button** to conclude the test.
8. At completion of the test, the test data is automatically saved in the onboard memory and can be recalled and exported to the USB flash drive at a later time. See **Reports Screen** on page 51.

NOTE: See **Calibrating sensors** on page 52 for details about calibrating specific sensor types.

PureWave™ Overview

PureWave is the distortion compensation algorithm. It reduces total harmonic distortion (THD), correcting up to 30 harmonics. The status of PureWave is indicated by the color of the reference data point:

- **Orange** = Not Ready
- **Blue** = Adjusting
- **Green** = Complete

Bearing Defect Screen

The Bearing Defect screen simulates bearing fault signatures for diagnostic training and system validation. This specialized simulation mode generates repeatable, defect signatures, and realistic vibration patterns characteristic for three common bearing defects: outer race faults, inner race faults, and cage (ball-pass) faults. The shaker will output a pulse, followed by ringing. The screen provides control over fault frequency, vibration amplitude, ball count, and sensor response characteristics.

NOTE: RMS mode is disabled. Bearing fault analysis requires peak measurements to properly identify impact events.

The benefits/applications of the Bearing Fault mode:

- Verify analyzer fault detection algorithms.
- Demonstrate analyzer capability safely (no rotating machinery).
- Train technicians in spectral identification.
- Support R&D sensor characterization.

Bearing Defect Screen Overview

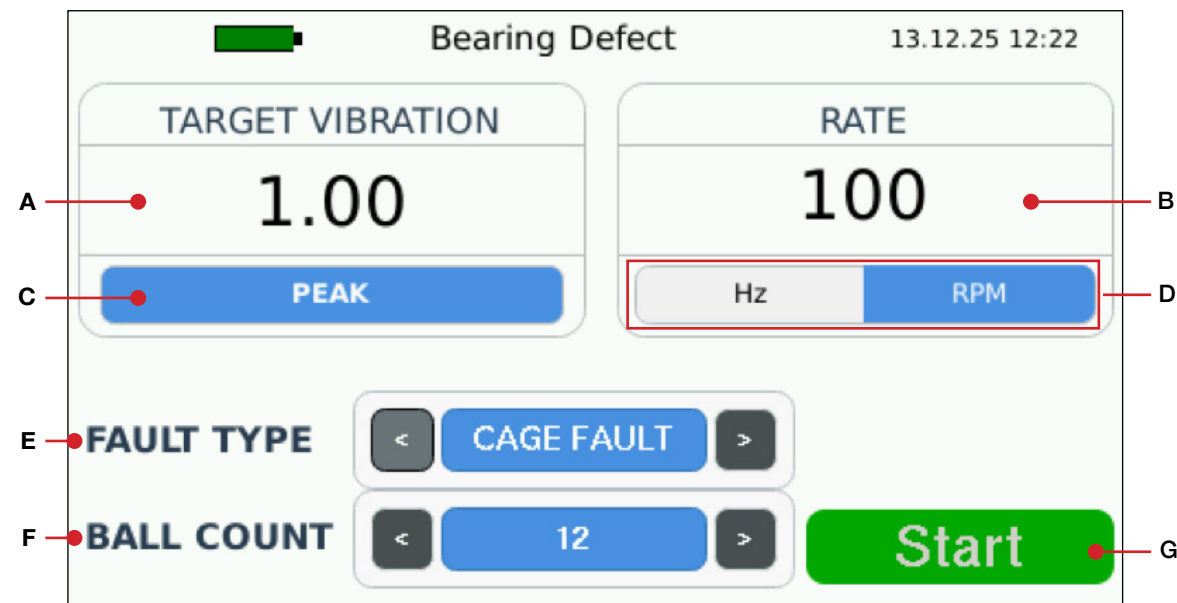

Figure 13

- Target Vibration Input/Display:** Turn the amplitude knob to adjust, or tap the touchscreen display to bring up the number pad and enter the amplitude test point.
- Rate Input/Display:** Turn the frequency knob to adjust, or tap the touchscreen display to bring up the number pad and enter the frequency or RPM test point.
- Peak:** RMS mode is disabled. Bearing fault analysis requires peak measurements to properly identify impact events.
- Hz and RPM Toggles:** Select the toggles to switch between the Hz and RPM.

- Fault Type:** Select the left and right arrow buttons to toggle through the failure/waveform type options: Outer Face, Inner Face, and Cage Fault (See *Table 4 Bearing Fault Patterns and Behavior*).
- Ball Count:** Tap the left and right arrow buttons to bring up the number pad and enter the number of balls in the bearing.
- Start/Stop Button:** Tap the onscreen button or use the frequency knob to select the button to start or stop the test.

Fault	Description	Fault Pattern	Characteristic Behavior
Outer Face	Ball pass frequency outer race (BPFO).	Simulates a defect on the stationary outer race. Impact occurs each time a rolling element passes the defect.	Most common bearing fault type (45–50% of failures).
Inner Face	Ball Pass Frequency Inner (BPFI).	Simulates a defect on the stationary inner race. Impact pattern varies with shaft position.	Second most common bearing fault type (35–40% of failures).
Cage Fault	Fundamental Train Frequency (FTF).	Simulates a defect in the bearing/cage separator.	Less common, but critical fault (10–25% of failures).

Table 4 Bearing Fault Patterns and Behavior

Conducting a Bearing Defect Test

NOTE: Before beginning the test, the failure type, number of balls, amplitude, and frequency may be adjusted.

- From the main menu, select **Bearing Fault** to open the Bearing Defect screen (*Figure 13*).
- Select your sensor and mount it to the ¼-28 drill hole in the reference accelerometer.
 - Hold the reference accelerometer with the provided short-handle wrench and screw in the sensor at the same time.
 - When necessary, use the correct sensor adapter for your size.
- To adjust the amplitude and/or frequency, turn the knobs or select a touchscreen display to bring up the number pad and enter the required value.
- Use the **Fault Type** **<** and **>** buttons to choose the fault/waveform type: Cage Fault, Inner Race, or Outer Race.
- Use the **Ball Count** **<** and **>** buttons to set the number of balls in the bearing.
- Select the **Start** button to begin the test.
- Select the **Hz** or **RPM** toggles to switch between frequency and speed.
- Select the **Stop** button to conclude the test.

NOTES:

- Any changes made to the failure type, number of balls, frequency, and amplitude will change the waveform.
- See example time spectrum waveforms (*Figure 14* and *Figure 15*).
- The signal polarity of the waveform may be changed to positive (+) or negative (–) in the Settings Menu. See **Changing the Bearing Fault Polarity** on page 41.

Examples

APPLICATION NOTE: Bearing faults produce impulsive vibration events rather than steady-state sinusoidal signals. The bearing fault simulation function generates repeatable impulse patterns with realistic decay characteristics, allowing users to verify monitoring systems, alarm logic, and signal processing behavior without the need for a physically damaged bearing.

Single Fault Event (High Time Resolution)

- *Figure 14* shows a single bearing fault event at high time resolution. The waveform consists of a sharp impulse followed by a decaying oscillation.
- The initial impulse represents the moment a rolling element contacts a localized defect on a bearing component, such as an inner race, outer race, rolling element, or cage. This impact produces a rapid rise in signal amplitude with broadband frequency content.
- The oscillation that follows is the natural ring-down response of the system, representing the mechanical resonance excited by the impact. The amplitude of this response decays over time as the energy dissipates.
- This behavior is characteristic of real bearing defect events and differs from continuous or sinusoidal vibration signals.

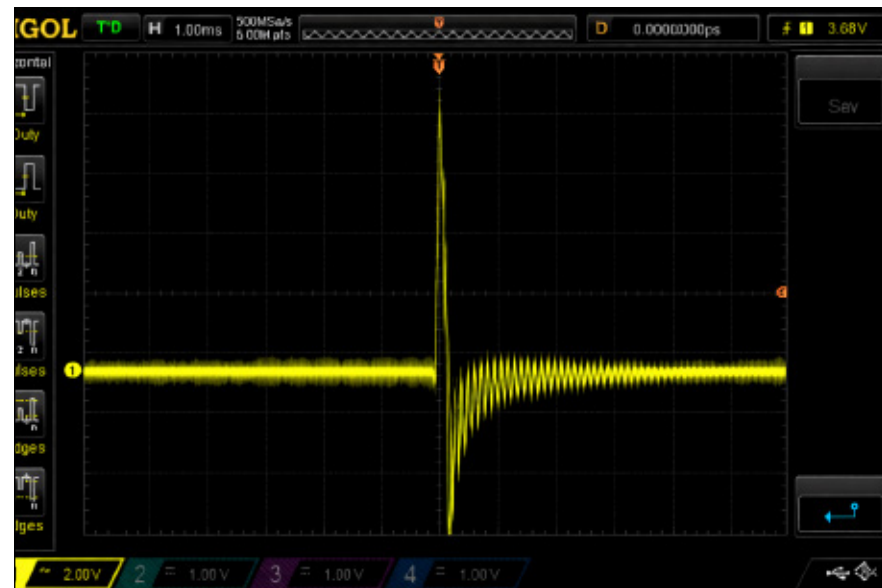

Figure 14

Repeating Fault Events (Lower Time Resolution)

- *Figure 15* shows multiple bearing fault events over a longer time scale. Each impulse corresponds to a rolling element repeatedly passing over the same localized defect.
- The spacing between impulses represents the bearing fault frequency and remains consistent over time. The amplitude and shape of each impulse are repeatable, producing a stable and predictable fault pattern.
- This type of waveform is used by condition monitoring systems to identify bearing defects through envelope detection, shock pulse analysis, and alarm threshold monitoring.

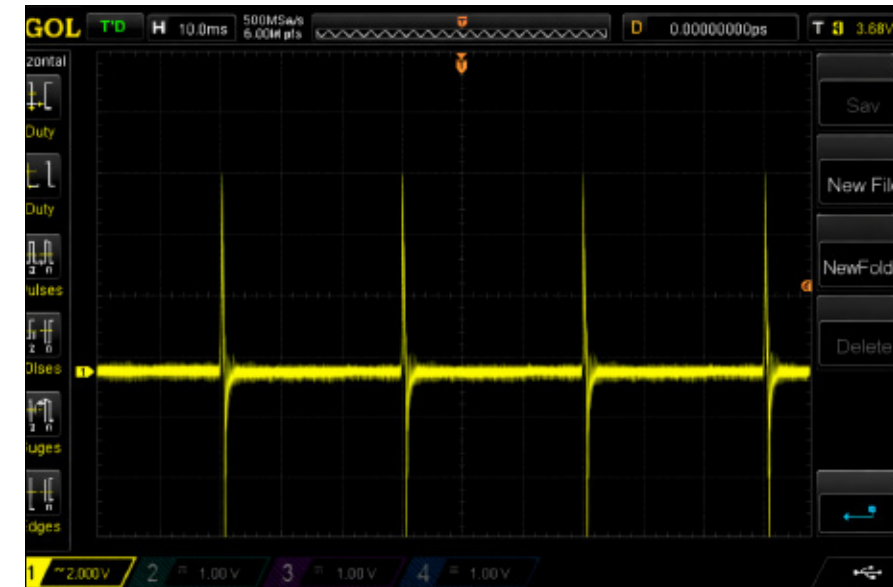

Figure 15

Sensor Test Screen

The Automatic Test Setup screen allows configuration of all test parameters directly on the device. Users define frequency range, amplitude, dwell time, and point count onscreen. Configurations are stored in an internal SQL database and remain available until deleted.

⚠ WARNING: Operator-Controlled Decision Making. Pass/fail decisions are intentionally excluded to prevent misinterpretation of user uncertainty budgets.

COMPLIANCE NOTE: The AT-2040 Gen 2 provides progress indicators but does not determine pass/fail outcomes. This preserves ISO 17025 and ANSI/NCSL Z540 compliance by allowing each laboratory to apply its own decision rule.

1. From the main menu, select **Sensor Test** to begin an auto sensor test.
2. Select the manufacturer (*Figure 16*).

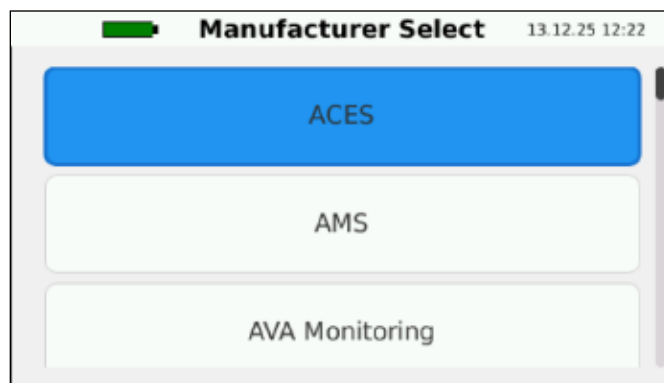

Figure 16

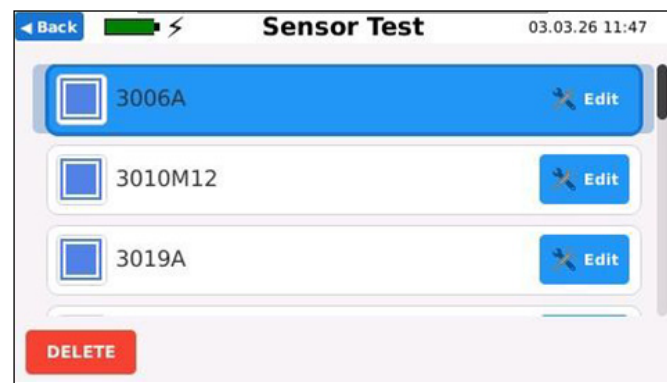

Figure 17

3. From the list of sensors available in the database (*Figure 17*), the operator can perform 3 actions:
 - a. **To begin sensor the test:** Select the sensor, then click the **Start button** in the bottom-right corner of the screen. **NOTE:** If the sensor is not in the database, you can add a custom sensor. See detailed instructions in **Test Setup Screen** on page 45.
 - i. The automatic test will run. Data is displayed, by default, in graph view.
 - ii. Select the **Table/Graph button** to toggle between graph view (*Figure 18*) and table view (*Figure 19*). Table view shows each of the test points for the test. When the test is in progress, the test point data will fill in, one row at a time. The test is complete when all data is filled in.
 - iii. Select the **Stop button** to stop/pause the test.
 - iv. At completion of the test, the test data is automatically saved in the onboard memory and can be recalled and exported to the USB flash drive at a later time. See **Reports Screen** on page 51.
 - b. **To edit the sensor:** Select the **Edit button** on the right side of the sensor name. See **Test Setup Screen** on page 45.
 - c. **To delete the sensor:** Select the **checkbox** on the left side of the sensor name, then select the **Delete button**.

Reviewing Automatic Test Data

The test data is shown by default in graph view. Select the **Graph/Table button** to toggle between graph and table view.

Graph View

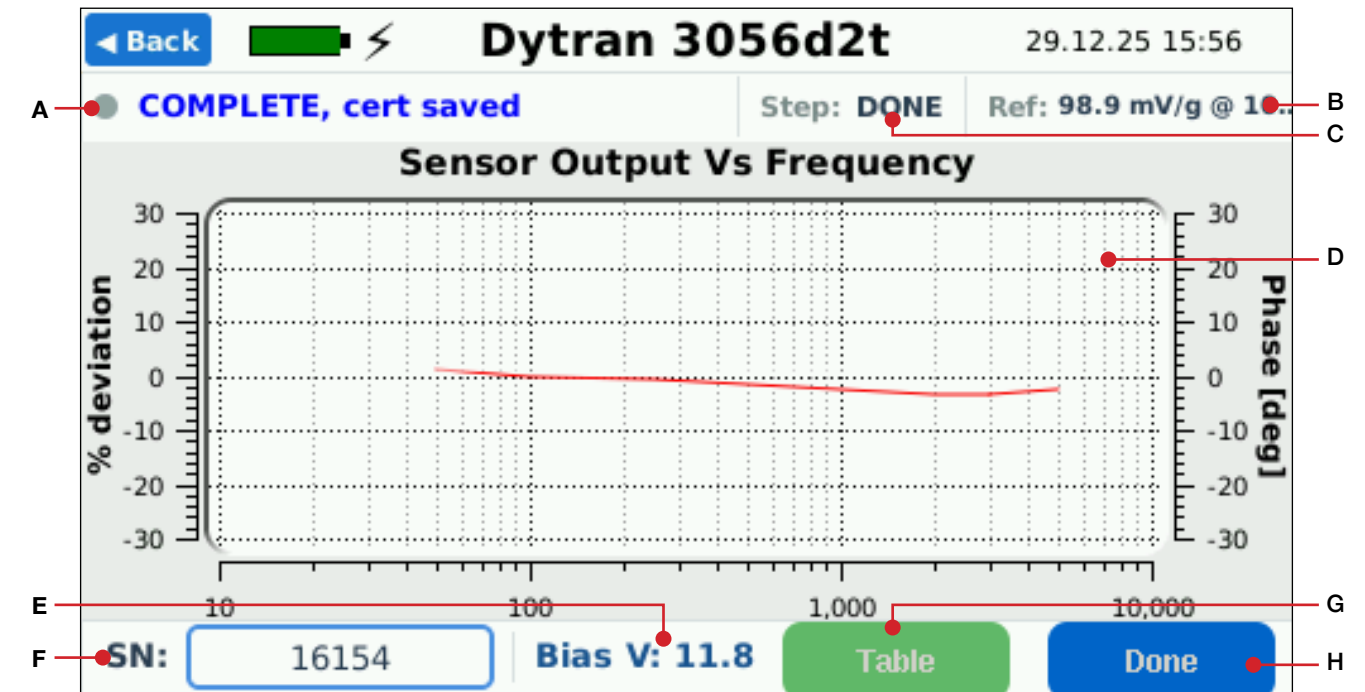

Figure 18

- A. **Test Status:** Provides information about the test as the calibrator automatically sweeps through the pre-defined test points.
 - **Ready:** Test not started. (Black)
 - **Testing:** Test in progress. (Black)
 - **Stopped:** Test stopped but not complete. (Red)
 - **Complete:** Test complete. (Blue)
- B. **Ref:** Shows the reference measurement taken at the start of the test.
- C. **Step:** Shows the current step and total number of steps, for example, 1/7 or 2/7. When the test is complete, "DONE" is shown.
- D. **Graph:** Shows deviation relative to the reference sensitivity.
- E. **Bias/Gap Voltage:** Shows the bias voltage when an IEPE sensor is selected, and gap voltage is shown when a proximity probe is selected.
- F. **Serial Number Input:** Shows the sensor serial number (which is printed on the certificate).
- G. **Table/Graph Button:** Select the button to switch between graph view and table view in real time.
- H. **Start/Stop Button:** Select the button to start or stop/pause the test.

Table View



Figure 19

- A. **Test Table:** "Running" indicates the current stage when the test is in progress.
 - **Test Points:**
 - **Frequency Column:** Test point frequencies.
 - **Amplitude Column:** Test point amplitudes.
 - **Test Results:**
 - **Sensitivity Column:** The sensor's sensitivity at the tested frequency and amplitude.
 - **Deviation Column:** Deviation in percentage relative to the reference frequency.
 - **Phase Column:** Shows polarity and signal delay.
- B. **Bias/Gap Voltage:** Shows the bias voltage when an IEPE sensor is selected, and gap voltage is shown when a proximity probe is selected.
- C. **Serial Number Input:** Shows the sensor serial number (which is printed on the certificate).
- D. **Graph/Table Button:** Select the button to switch between graph view and table view in real time.
- E. **Start/Stop Button:** Select the button to start or stop/pause the test.

Signal Simulation Screen

The Signal Simulator is a versatile signal generation tool integrated into the AT-2040 calibration system. It enables operators to generate accurate vibration signals that replicate the electrical output of nine different sensor types. This capability is essential for system verification, technician training, and validating data acquisition equipment without requiring physical sensors or shakers.

The simulator has a significant advantage over the electrodynamic shaker when calibrating analyzers and control equipment because it is not bound by mechanical limitations. The simulator feature can provide high-output signals at low frequency that would otherwise not be possible due to shaker displacement limitations. Similarly, the shaker can provide high-frequency signals that otherwise would not be possible due to weight limitations. The simulator output by itself is far more accurate than using the electrodynamic shaker in combination with an accelerometer. This makes simulation mode the ideal tool for testing, troubleshooting, and calibrating signal conditioners, analyzers, and control room equipment. Simulation mode allows the operator to connect the shaker's simulator directly to control equipment to verify its working conditions.

Signal Simulation Mode generates electrical vibration signals without physical motion. Real-time relay switching allows selection of IEPE, Charge, Voltage, 4–20 mA, or Proximity Probe outputs. Signals are expressed in vibration units (g, IPS, mils) for realistic simulation of sensor behavior. This mode acts like a vibration-specific function generator, enabling analyzer verification and system testing. Signal Simulation Mode has the following applications:

- Verify analyzer channels and scaling.
- Calibrate control equipment.
- Train personnel on vibration analysis.
- Evaluate new sensor electronics.

Sensor Type	Signal Type	Default Sensitivity	Available Units	Bias Voltage	Applications
IEPE Accelerometer	AC voltage with DC bias	100 mV/g	mV/g, mV/m/s ² , V/g	Configurable 0-24 V (default: 10 V)	Most common industrial accelerometer type
Charge Accelerometer	Charge output (picocoulombs)	100 pC/g	pC/g, pC/m/s ²	N/A	High-temperature applications, low-noise measurements
Voltage Accelerometer (DC/AC)	Voltage output (DC or AC coupled)	100 mV/g	mV/g, mV/m/s ² , V/g	N/A	MEMS sensors, low-cost monitoring
Piezo Velocity Sensor	AC voltage proportional to velocity	100 mV/IPS	mV/IPS, mV/mm/s, V/IPS	N/A	Machine protection, low-frequency monitoring
Moving-Coil Velocity Pickup	AC voltage proportional to velocity	100 mV/IPS	mV/IPS, mV/mm/s, V/IPS	N/A	Seismic pickups, legacy systems
Eddy-Current Proximity Probe	DC voltage with AC ripple	200 mV/mil	mV/mil, mV/μm, V/mil	Typically -8 V to -12 V DC offset	Shaft displacement, bearing clearance
Displacement Probe (Generic)	Voltage output proportional to position	200 mV/mil	mV/mil, mV/μm, V/mil	Varies by sensor	General position sensing
MEMS Accelerometer	DC/AC voltage output	100 mV/g	mV/g, mV/m/s ² , V/g	N/A	Consumer electronics, automotive
4–20 mA Transmitter	Current loop (4–20 mA)	1.0 g/FS	g/FS, m/s ² /FS, IPS/FS, mm/s/FS, mil/FS, μm/FS	Linear 4–20 mA based on vibration amplitude vs. full-scale	Industrial PLCs, SCADA systems

Table 5 Supported Sensor Types

Simulation Screen Overview

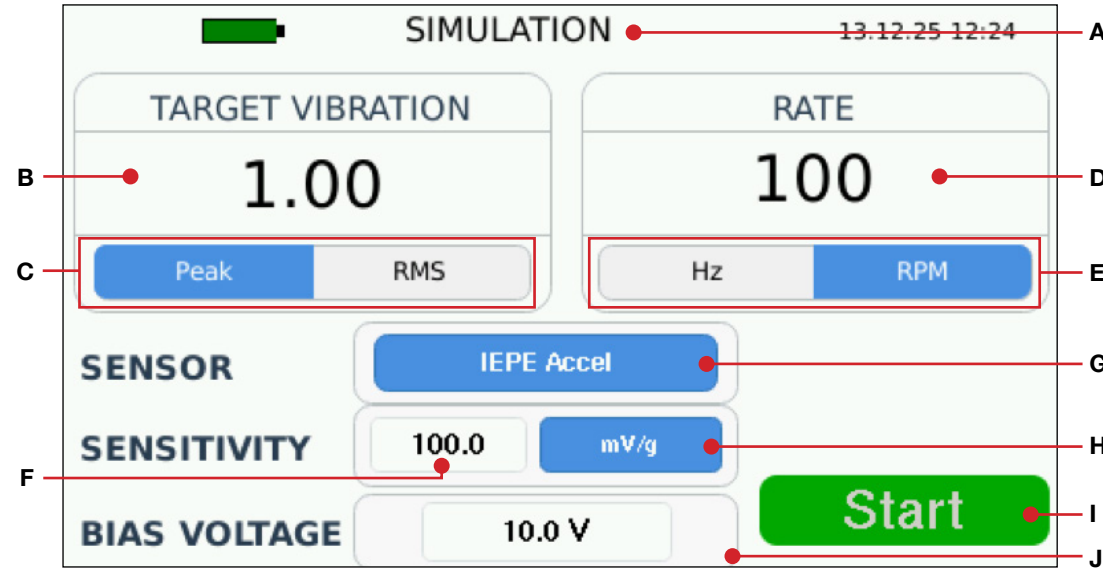

Figure 20

- A. **Sensor Type:** Shows the current sensor type, for example, "IEPE Simulator". "RMS" is appended to the end of the sensor title when RMS mode is active.
- B. **Target Vibration Input/Display:** Turn the amplitude knob to adjust, or tap the touchscreen display to bring up the number pad and enter the amplitude test point.
- C. **Peak and RMS Toggles:** Tap to toggle between Peak and RMS.
- D. **Rate Input/Display:** Turn the frequency knob to adjust, or tap the touchscreen display to bring up the number pad and enter the frequency or RPM test point.
- E. **Hz and RPM Toggles:** Tap to toggle between frequency and speed.
- F. **Sensor Type Button:** Select to choose from the nine available sensor types.
- G. **Sensitivity Input:** Select to enter the sensor's rated sensitivity (from the datasheet).
- H. **Sensitivity Units Button:** Select to toggle through the available sensitivity units.
- I. **Start/Stop Button:** Tap the onscreen button to start/stop the simulation.
- J. **Bias Voltage Input:** Select to enter the bias voltage (if applicable to the selected sensor).

Using Simulation Mode

To begin a simulation:

1. Choose **Signal Simulation** from the main menu to open the Simulator screen (Figure 21).
2. Connect your equipment to the sensor simulator output.
 - a. If simulating an IEPE or charge mode accelerometer, use the BNC Sensor Simulation Output jack.
 - b. If simulating a 4–20 mA or proximity probe ():
 - i. Use the Proximity Probe Output Simulator (labeled "1") for a prox simulator.

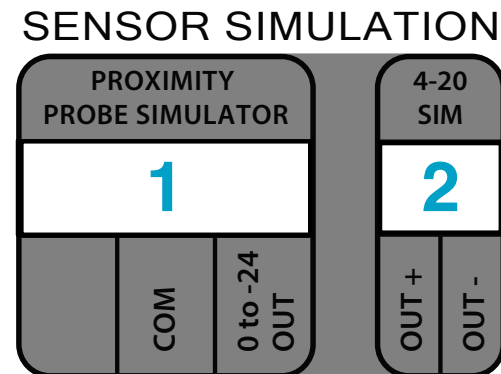

- ii. Use the 4–20 mA Sensor Output Simulator (labeled "2") for a 4–20 mA simulator.
3. Select the **Sensor Type button** (Figure 22).



Figure 21

SELECT SENSOR TYPE		
IEPE Accelerometer	AC voltage	mV/g
Charge Accelerometer	Charge (pC)	pC/g
Voltage Accelerometer (DC/AC)	Voltage	mV/g
Piezo Velocity Sensor	AC voltage	mV/IP5
Moving-Coil Velocity Pickup	AC voltage	mV/IP5
Eddy-Current Proximity Probe	DC + AC ripple	mV/mil
Displacement Probe (generic)	Voltage	mV/mil
MEMS Accelerometer	DC/AC voltage	mV/g

Figure 22

4. Choose from the list of available sensors.
 - a. Refer to *Table 5 Supported Sensor Types* for detailed information about each sensor type.
 - b. The signal type (gray) and default sensitivity units (green) are shown to the right of each sensor. The default sensitivity units populate the screen automatically when the sensor is selected.
5. Select the **Sensitivity Value input**, and use the onscreen number pad to enter the sensor's rated sensitivity (from the sensor datasheet).
6. Select the **Sensitivity Units button** to choose from the available sensitivity units for the sensor type ().
7. Select the **Bias Voltage input**, if applicable for the selected sensor, and use the onscreen number pad to enter the DC bias (typically 10 V).
8. Use the rotary knobs or touch screen to set:
 - a. **Amplitude:** Target vibration level.
 - b. **Frequency:** Test frequency in Hz or RPM.
 - c. **Units:** Desired vibration measurement units.
 - d. **RMS/Peak:** Measurement mode.
9. Select the **Start button** to begin the simulation.
10. While the simulation is running, the shaker will precisely mimic a transducer being operated at the chosen amplitude and frequency.
11. Select the **Stop button** to conclude the simulation.



Settings Screen

1. On the main screen, select **Settings** to open the Settings screen. The Settings screen (*Figure 23*) has the following options:
 - a. **Date & Time:** Set the date, time, and time zone.
 - b. **Network:** Set up the Wi-Fi or Ethernet network.
 - c. **Import File:** Export the default PDF certification template, or import the user-customized PDF certification template and company logo image file.
 - d. **Unit Configuration:** Set the company name, change the signal polarity, or calibrate the mass load correction.
 - e. **Unit Info:** View the shaker information including, serial number, firmware and FPGA version.
 - f. **Test Setup:** Create a custom sensor.

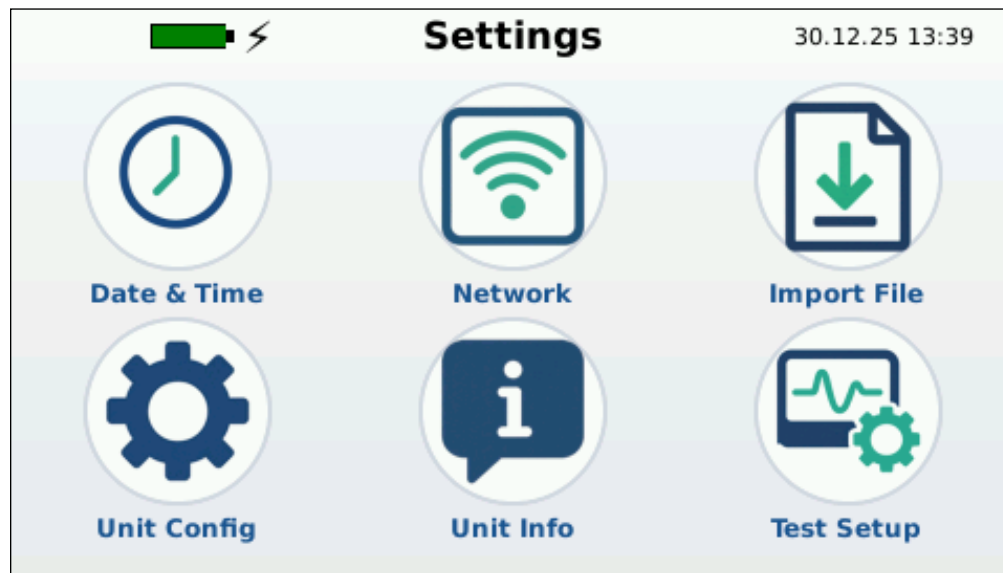

Figure 23

Date & Time Settings Screen

1. On the Settings screen, select **Date & Time**.
2. On the Date & Time Settings screen (*Figure 24*), set the time and date:
 - a. Select the **Hour** and **Minute inputs** to set the time. The time displays in 24-hour format (HH:MM:SS).

- b. Select the **Year, Month, and Day inputs** to set the date. The date displays in MMM DD, YYYY format.



Figure 24

3. Select the **Region** and **City/Area inputs** to set the time zone.
4. Select the **Save button** to confirm changes.

Network Settings Screen

1. On the Settings screen, select **Network**.
2. On the Network Settings screen (*Figure 25*), the current network status can be viewed, and the wireless (Wi-Fi) and wired (Ethernet) network connections on the AT-2040 may be configured.

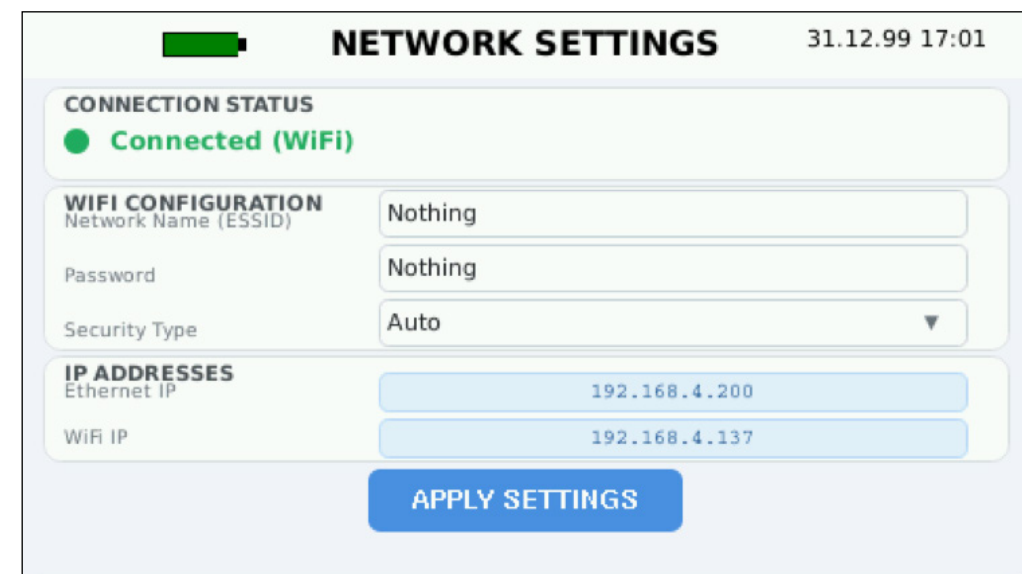

Figure 25

3. To connect to the AT-2040 via Wi-Fi:

- a. In the WiFi Configuration section, select the **Network Name (ESSID) input** (Figure 26) to open the onscreen keypad.
- b. Enter the identifying name of your Wi-Fi network. This is the ESSID, also known as an SSID.
NOTE: Network names are case sensitive; ensure exact spelling and capitalization.

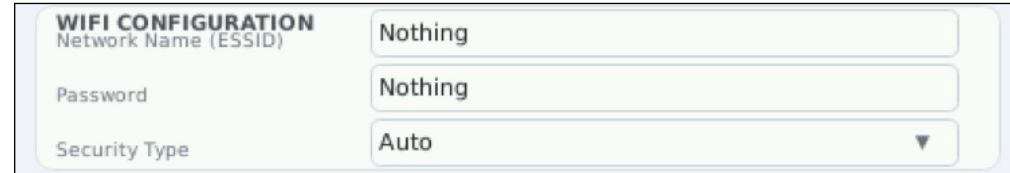

Figure 26

- c. Select the **Password input** and enter the wireless network password.
NOTE: Passwords are case sensitive. Include all special characters exactly as they appear.
- d. Select the **Security Type dropdown list** to toggle through the four security options:

Wi-Fi Security Type	When to Use
Auto (Default)	Let system automatically detect security type (recommended)
Open	Unsecured network with no password
WPA/WPA2	Most modern Wi-Fi networks (most common setting).
WEP	Legacy networks with older encryption.

- e. Select the **Apply Settings button** to save the network configuration.

4. To connecting to the AT-2040 via Ethernet:

- a. Plug a USB-to-Ethernet adapter into the USB port.
- b. An IP address will automatically be assigned by the network. The assigned IP address appears in the IP Address section of the screen:

IP Address	Meaning
0.0.0.0	No Wi-Fi connection active.
xxx.xxx.xxx.xxx	Valid IP address assigned by the network.
Searching	Attempting to obtain IP address.

- c. The IP address automatically updates every 5 seconds. **NOTE:** The IP address cannot be manually edited by the user.

5. To view the current network status:

- a. The current network status is displayed at the top of the screen in the Connection Status section, and updates automatically every 5 seconds:

Status	Definition
● Connected (WiFi)	Active Wi-Fi connection with valid IP address.
● Connected (Ethernet)	Active Ethernet connection with valid IP address.
● Disconnected	No active network connection.

Certificate Import/Export Screen

The shaker can automatically generate a sensor calibration certificate. The calibration certificate can be customized to your specific business needs and branding. See the sample certification template (Figure 28) at the end of this section.

1. On the Settings screen, select **Certificate Import/Export**.
2. On the Certificate Import/Export screen (Figure 27), you can check the connection status of a USB flash drive, see the file name of the current certificate template, import a certificate template from USB, or export (save) a template file to USB:

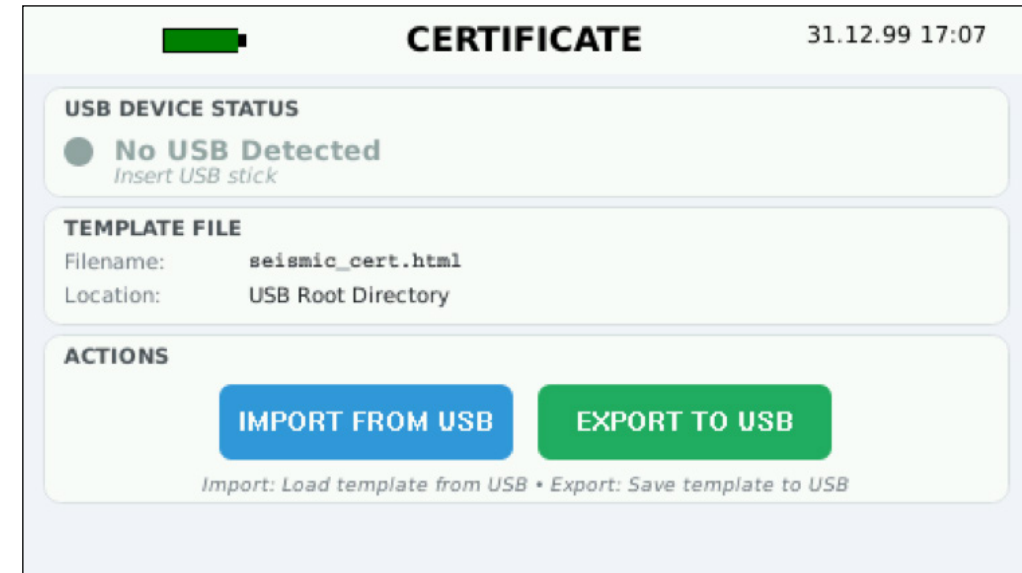

Figure 27

3. Connect a USB flash drive to the AT-2040:
 - a. Power off the AT-2040. **NOTE:** The shaker must be powered off to load a USB flash drive.
 - b. Insert the USB flash drive into the USB slot. Then, power on the AT-2040.
 - c. The connection status of the flash drive will be displayed at the top of the screen:

Status	Definition
● USB Connected	USB flash drive plugged into the AT-2040.
● USB Disconnected	No USB flash drive is present.

- d. The file name and location of the current certificate template are shown in the Template File section.
4. Export the default template files:
 - a. Select the **Export To USB button** to export the shaker's default calibration certificate template files, **seismic_cert.html** and **logo.png**, to the USB flash drive.
 - b. Remove the flash drive, and then plug it into your computer.

5. Customize and save the template files:
 - a. Customize the **seismic_cert.html** file as needed. See **Appendix B** on page 83 for detailed PDF certificate customization information and tips.
 - b. Once customized, save the HTML file to the USB flash drive. **IMPORTANT: Do not change the name of the HTML file.**
 - c. Save your company logo to the USB flash drive. Rename your company logo: **logo.png**. If prompted by your computer, choose to replace the old logo.png file with the new logo.png file you are saving now.
 - d. Power the AT-2040 off, and insert the USB flash drive into the shaker's USB slot.
 - e. Power on the shaker.
6. On the **Settings** screen, select **Certificate Import/Export**.
7. Select the **Import From USB** button to import your customized HTML certificate template, **seismic_cert.html**, and your company logo file, **logo.png**.

Sample Certification Template

The sample certification (*Figure 28*) shows the following information:

- A. **Company:** Company name.
- B. **Manufacturer:** Sensor manufacturer name.
- C. **Model:** Sensor model number.
- D. **Serial #:** Serial number of the sensor.
- E. **REF Sensitivity:** Sensitivity at the reference frequency.
- F. **Frequency HZ:** Test point frequencies.
- G. **Amplitude (GS):** Test point amplitudes.
- H. **Sensitivity (mV/g):** Test point sensitivities.
- I. **Deviation Relative to 100 Hz:** Deviation in percentage relative to the to reference frequency.
- J. **Graph:** Graph relative to the deviation of the reference frequency (visual representation of item I).
- K. **Calibration Tech:** Tech name.
- L. **Test Date:** Calibration date.

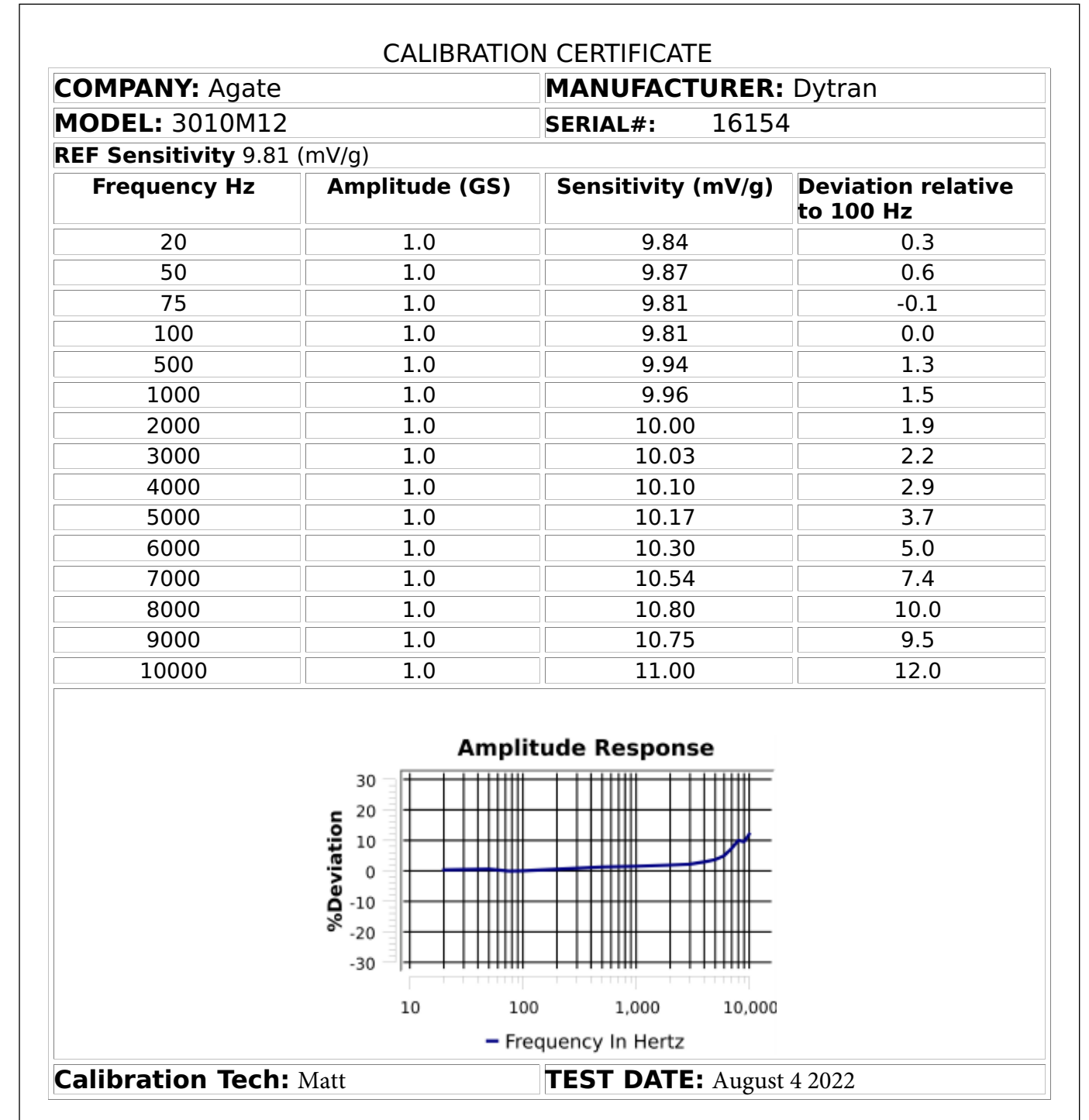

Figure 28

Unit Configuration Screen

1. On the Settings screen, select **Unit Configuration**.
2. On the Unit Configuration screen (*Figure 29*), you can change the company name, change the bearing fault polarity to positive or negative, adjust the screen brightness, or calibrate the mass load correction:

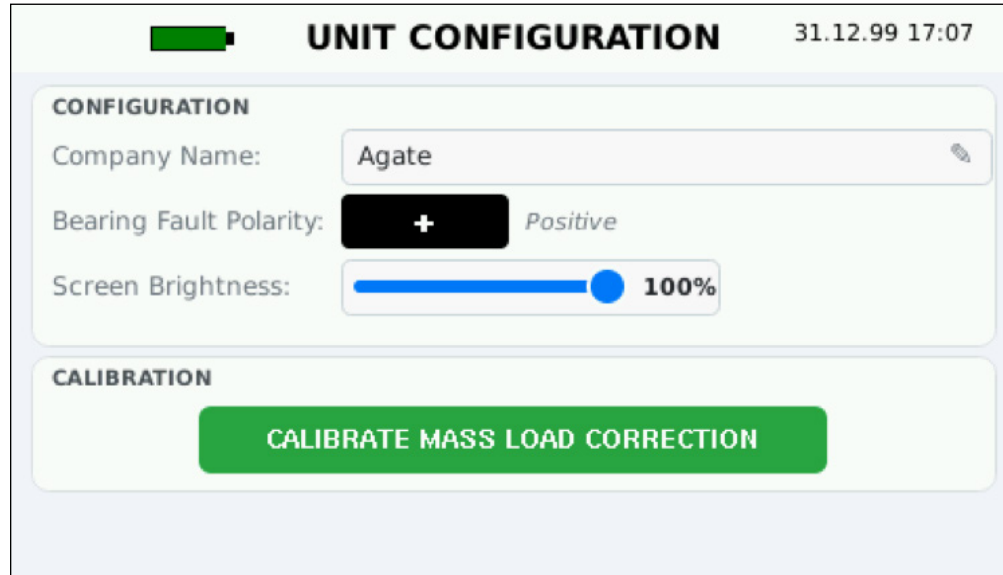

Figure 29

Changing the Company Name

The company name appears on all generated calibration reports. To change it:

1. On the Unit Configuration screen, select the **Company Name input** at the top of the screen to open the onscreen keypad.
2. Enter the company name (*Figure 29*).
 - a. The maximum length is 50 characters. Alphanumeric characters and spaces are accepted; symbols are not accepted.
3. Tap the **OK button** to save, or the **Cancel button** to close the keypad without saving.
4. The company name will be updated immediately.

Changing the Bearing Fault Polarity

This setting configures the polarity setting for bearing fault detection measurements. It determines whether positive (+) or negative (-) polarity is used when analyzing bearing defects.

To change the polarity:

1. On the Unit Configuration screen, select the **- / + button** next to Bearing Fault Polarity to toggle the signal polarity between negative and positive (*Figure 29*):

Polarity	Button	When to Use
Positive (+)		Standard configuration for most bearing fault analysis. Selected by default.
Negative (-)		Use when analyzing specific fault conditions that require negative polarity detection.

2. The selected polarity is saved automatically.

NOTES:

- This setting affects how bearing defects are detected and reported.
- Consult with your vibration analysis specialist if unsure which polarity to use.
- The setting persists across power cycles.

Adjusting the Screen Brightness

The screen brightness is adjusted via the Screen Brightness slider in the middle of the screen. The current brightness level, from 0 to 100%, is shown to the right of the slider.

1. To adjust the screen brightness:
 - a. **Touch and drag** the slider left to lower the brightness or right to increase the brightness. The screen brightness adjusts automatically in real-time as you drag the slider. Release the slider to set the brightness level. **OR**
 - b. **Tap** anywhere along the slider track to jump to a brightness level.

Brightness Ranges	When to Use
0%	Minimum brightness Very dim, suitable for dark environments.
50%	Medium brightness Suitable for indoor use.
100%	Maximum brightness Suitable for bright outdoor conditions.

2. The selection is saved automatically.

Tips for Selecting Screen Brightness:

- Lower brightness settings conserve battery power.
- Higher brightness settings improve visibility in bright sunlight.
- Adjust to personal preference and ambient lighting conditions.
- The brightness setting persists across power cycles.

Calibrating the Mass Load Correction

This setting performs calibration to correct for the mass of the shaker head and any attached fixtures. This ensures accurate vibration measurements by accounting for the weight added to the test system.

WHEN TO PERFORM A CALIBRATION

- After replacing the shaker head.
- If measurement accuracy is questionable.
- As part of regular maintenance schedule (recommended: annually).

REQUIREMENTS

- Remove ALL weight from the shaker head before calibration.
- System must be powered on and warmed up (minimum 15 minutes).
- Shaker must be in a stable, level position.
- Passcode required: 555.

CALIBRATION STEPS

Step 1: Prepare the System

1. Place the shaker on a stable, level surface.
2. Remove all test items, sensors, and fixtures from the shaker head. The shaker will calibrate incorrectly if the sensor/payload is not removed.
3. Ensure the shaker head is completely unloaded
4. Verify the system has been powered on for at least 15 minutes

Step 2: Access Calibration

1. On the Unit Configuration screen, select the **Calibrate Mass Load Correction button** to open the Mass Load Correction screen (*Figure 30*).

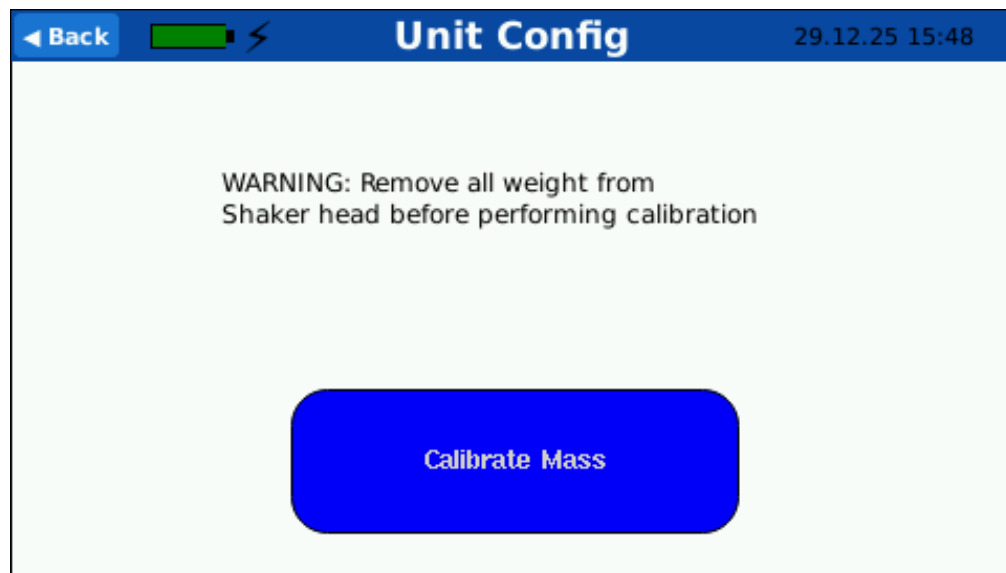

Figure 30

Step 3: Read Warning

1. A warning message will display: "WARNING: Remove all weight from shaker head before performing calibration".
2. Verify that all weight has been removed.

Step 4: Initiate Calibration

1. Select the blue **Calibrate Mass button**.
2. The onscreen number pad will open with the prompt "Enter Passcode."

Step 5: Enter Passcode:

1. Enter passcode to confirm calibration:
 - a. Enter the passcode **555**.
 - b. Select the **OK button** to proceed; OR Tap **Cancel** on the number pad to exit without calibration; the system will return to the Unit Configuration screen immediately.
2. **Correct Passcode Entered: Calibration Process**
 - a. The screen will show "Calibrating", and the mass load correction calibration will begin.
 - b. **Do NOT disturb the shaker during the calibration process**; it typically takes 10–30 seconds.
 - c. When calibration is complete, the system will show "Calibration Done," and the system will return to the Unit Configuration screen after 3 seconds.
3. **Incorrect Passcode Entered:**
 - a. If an incorrect passcode is entered, the screen will show "Bad Passcode."
 - b. The system will return to the Unit Configuration screen after 3 seconds.
 - c. Repeat the steps to try again.

NOTES:

- Calibration data is saved automatically upon completion.
- The passcode prevents accidental calibration.
- If calibration fails or seems incorrect, repeat the process.
- Contact technical support if repeated calibration attempts fail.

Unit Info Screen

1. On the Settings screen, select **Unit Info**.
2. The Unit Information screen (*Figure 31*) displays the following information:

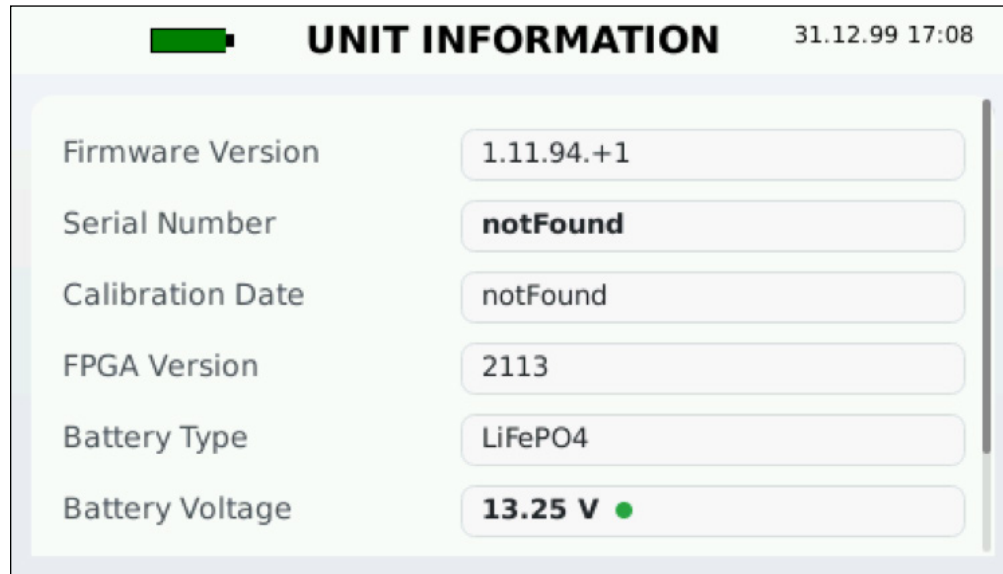

Figure 31

- a. **Firmware Version**
- b. **Serial Number**
- c. **Calibration Date** (Last factory calibration date)
- d. **FPGA Version**
- e. **Battery Type** (LiFePO4 (lithium iron phosphate))
- f. **Battery Voltage**
- g. **Ref BIAS Volts:** Internal reference bias voltage. Used for determining any drift in the reference accelerometer's DC bias voltage. The first value is the current DC measurement; the second is the measured value at the time of calibration.
NOTE: If no measurement was taken at the time of calibration, the second unit will show a value of "00".

Test Setup Screen

The Test Setup screen allows you to create custom sensor test configurations for sensors not in the standard database. This is useful for testing new sensors, experimental setups, or custom calibration procedures.

NOTE: The Manufacturer and Part Number inputs are required and cannot be empty.

Step 1: Planning Your Test (Before Creating the Custom Sensor)

1. **FIRST Review Amplitude Limits:** Check the frequency-dependent limits table before planning test points. See **Frequency-Dependent Amplitude Limits** on page 72.
2. **Start with Reference Point:** Define reference frequency and amplitude based on the calibration certificate.
3. **Plan Frequency Sweep:** Choose frequencies that cover the sensor's operating range.
4. **Use appropriate amplitudes:** Choose frequency and amplitude combinations that fall within the safe operating limits.
 - a. **Low frequencies (10-50 Hz):** Use reduced amplitudes below 5g
 - b. **Mid frequencies (50-1000 Hz):** Maximum amplitudes (10 g)
 - c. **High frequencies (3000+ Hz):** Must reduce amplitudes (0.5–5 g)
 - d. When in doubt, use lower amplitude values to ensure safe operation.

NOTE: Refer to the maximum weight table (*Figure 1*).

5. **Consider Sensor Limits:** Don't exceed the sensor's maximum input level.

Step 2: Entering the Custom Sensor Details

1. On the Settings screen, select **Test Setup** to open the Test Setup screen (*Figure 32*).

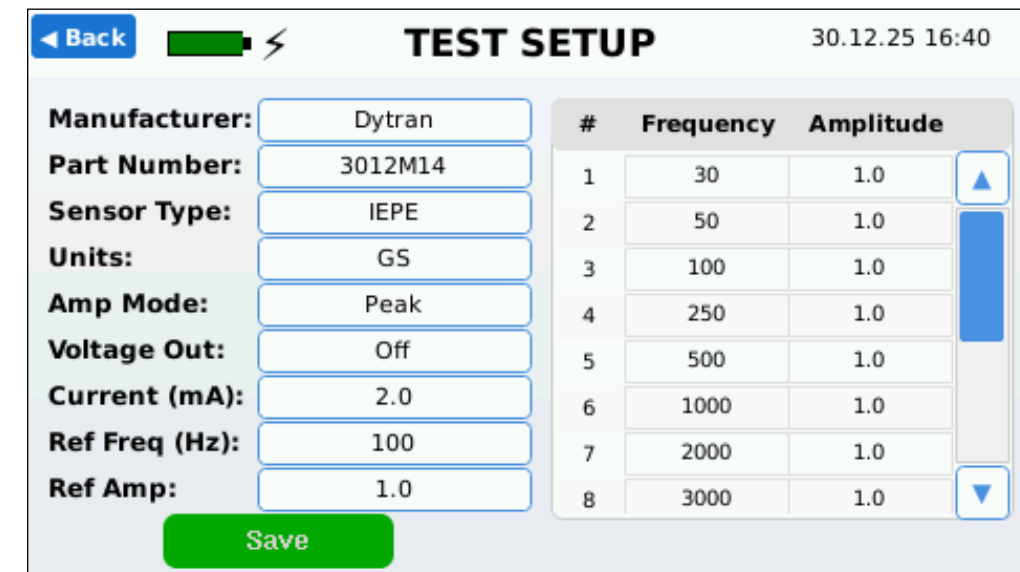

Figure 32

2. **Required:** Select the **Manufacturer input**, and enter the manufacturer name.

3. **Required:** Select the **Part Number input**, and enter the sensor model or part number. **NOTE:** The part number must be unique for this manufacturer. It identifies the specific sensor model and is used as the primary identifier in the database.
4. Select the **Sensor Type input**, and select the sensor type from the list:
 - a. **IEPE:** Integrated Electronics Piezo-Electric. IEPE is the most common and is selected by default.
 - b. **Charge:** Charge output sensors (requires charge amplifier).
 - c. **Voltage:** Direct voltage output sensors.
 - d. **Coil:** Velocity coil sensors.
 - e. **Transmitter:** 4–20 mA transmitters.
 - f. **Prox:** Proximity probes.

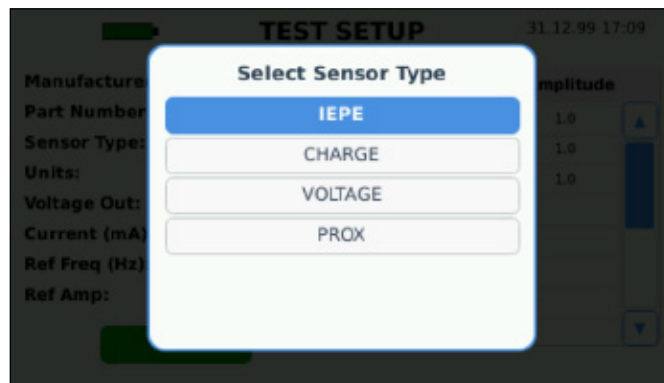

Figure 33

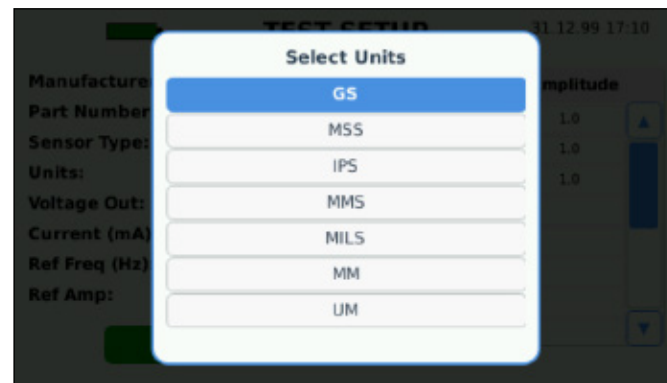
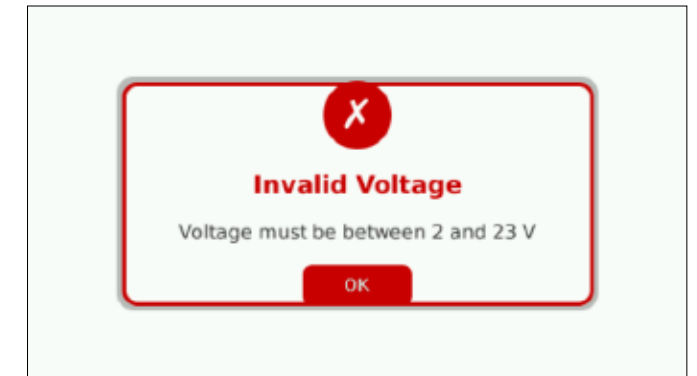

Figure 34

5. Select the **Units input**, and choose the measurement units for amplitude values:
 - a. **GS:** Acceleration in g (gravity units). GS is selected by default.
 - b. **MSS:** Acceleration in m/s²
 - c. **IPS:** Velocity in inches per second
 - d. **MMS:** Velocity in mm/s
 - e. **MILS:** Displacement in mils (0.001")
 - f. **MM:** Displacement in millimeters
 - g. **UM:** Displacement in micrometers
6. **IMPORTANT UNIT NOTES:**
 - a. Amplitude limits automatically convert to selected units.
 - b. Changing units does NOT change the test point values.
 - c. Choose units appropriate for your sensor type (use the same units as the sensor datasheet):
 - i. **Accelerometers:** GS or MSS (GS is most common; easy to understand)
 - ii. **Velocity Sensors:** IPS or MMS (IPS common in the US for velocity)
 - iii. **Displacement Sensors:** MILS, MM, or UM (MILS common in the US for displacement)
7. Select the **Amp Mode toggle**, and select RMS or Peak units.

8. Select the **Voltage Out input**, and enter the value for the parameter. The Voltage Out setting controls the adjustable auxiliary DC supply available on Pin 3 of the DIN connector. This output allows the user to provide a specified DC voltage to external devices or sensor circuits that require a user-defined supply. **NOTE:** The Voltage Out supply operates independently of the AT-2040's internal constant-voltage sensor power.
 - a. **Default:** 0.0 V | **Adjustable Range:** 2.0 to 23.0 V
 - b. **Output Location:** DIN connector, Pin 3
 - c. **Typical Applications:**
 - i. Supplying DC power to external signal-conditioning electronics.
 - ii. Powering non-IEPE sensors requiring a user-defined excitation voltage.
 - iii. Providing auxiliary power for custom test setups.
 - d. **Constant-Voltage Sensor Power (Reference):** In addition to the adjustable Voltage Out supply, the AT-2040 provides dedicated internal sensor power for common sensor types. These outputs are fixed, regulated supplies and are not affected by the Voltage Out setting.
 - i. **IEPE Sensors:** Internal constant-current excitation with approximately 24 V compliance.
 - ii. **Charge Sensors:** No excitation voltage required.
 - iii. **Transmitters:** Fixed 24 V supply.
9. **IEPE Sensors ONLY:** Select the **Current (mA) input**, and enter the excitation current for the IEPE sensor.
 - a. **Default:** 4.0 mA | **Adjustable Range:** 2.0 to 8.0 mA
 - b. **Validation:**
 - i. If you enter a value below 2.0 mA or above 8.0 mA, the system will show the error message: "Current must be between 2 and 8 mA."
 - ii. Correct the value and try again.
10. Select the **Ref Freq (Hz) input**, and enter the sensor's reference calibration frequency. This value defines the frequency at which the sensor's sensitivity is specified and is used as the reference for scaling measurement results. **NOTE:** The reference frequency is generated using integer clock division from a crystal oscillator; therefore, only fixed whole-number reference frequencies are supported.
 - a. **Default:** 100 Hz
 - b. **Typical Values:** 60 Hz or 100 Hz



- c. **Reference Frequency Selection by Location:** When plugged in, the reference frequency must be selected based on the local AC power-line frequency to avoid testing at a power-line frequency or one of its harmonics.
 - i. **60 Hz AC regions (e.g., United States):** Set Ref Freq = 100 Hz
 - ii. **50 Hz AC regions (e.g., Europe):** Set Ref Freq = 60 Hz
 - iii. This ensures the reference frequency is not a multiple of the local AC mains frequency, minimizing the influence of electrical interference.

D. **NOTES:**

- i. The reference frequency is the frequency at which the sensor’s sensitivity is defined and is typically listed on the sensor’s calibration certificate.
- ii. The reference frequency is not the same as the test point frequencies used during calibration or testing.
- iii. Avoid setting the reference frequency to the local AC power-line frequency or any integer multiple of it, as this can introduce mains-related noise and reduce measurement stability.

11. Select the **Ref Amp input**, and enter the calibration amplitude at the reference frequency.

- a. **Default:** 1.0
- b. **Units:** Uses the selected Units setting.
- c. **Common Values:**
 - i. **Standard Calibration:** 1.0 g (at 100 Hz)
 - ii. **Low-Level:** 0.5 g
 - iii. **High-Level:** 10.0 g

d. **NOTES:**

- i. This is NOT validated against shaker limits (reference only).
- ii. Value should match your calibration certificate.
- iii. Used for sensitivity calculations.

Step 3: Entering the Test Points and Validating

⚠ IMPORTANT SAFETY INFORMATION:

- **Do Not Override Limits:** These limits are based on shaker specifications and should not be exceeded.
- **Physical Damage Risk:** Exceeding amplitude limits can damage the shaker, test item, or sensors.
- **Void Warranty:** Operating outside specifications may void equipment warranty.
- **Operator Safety:** Excessive vibration can cause mechanical failures and safety hazards.

The test points table defines up to 15 frequency/amplitude combinations for your test sequence. Each test point specifies:

- **Frequency (Hz):** Test frequency (10–10,000 Hz)
- **Amplitude:** Vibration level in selected units

Best Practices for Entering Test Points

- Always enter test points in order from the top row down.
- Always set the frequency before the amplitude.
- Check amplitude limits for each frequency. See **Frequency-Dependent Amplitude Limits** on page 72.
- Use realistic values—always match typical calibration levels.
- Leave extra rows blank. Only fill in the rows you need.
- See **Appendix A** on page 72 for detailed test point validation information, including:
 - Test point validation process, including:
 - Frequency-dependent amplitude limits, as well as a quick reference guide in common units
 - Error message reference.
 - Troubleshooting common problems creating a custom sensor.
 - Technical reference, including data storage, validation rules summary, and amplitude limit conversion factors.

Enter the test points in the table on the right side of the Test Setup screen:

1. First, select the **Frequency cell** in the first row and enter the frequency.
2. Second, select the **Amplitude cell** in the first row and enter an appropriate amplitude for that frequency.
3. Complete all needed rows, from top to bottom. Leave any extra rows empty (only fill in the rows you need; not all tests will require 15 test points).
4. Editing test point values:
 - a. To cancel an edit: While the number pad is open, select the **ESC button**. The original value will be restored, and the number pad will close.
 - b. To delete a test point: select the cell. Select the **Clear button**, then **OK** to save.

- c. Up and Down arrows will appear on the right side of the table when the table has more entries than will fit on the screen. Use the arrow buttons to scroll up and down.
- 5. Select the **Save button** to save the custom sensor and test points. The system will validate all settings:
 - a. If validation fails:
 - i. The save is canceled, and an error dialog shows the problem. See example in *Figure 35*. Another example of a test point failing validation is, "Row [N]: At [freq] Hz, amplitude [amp] [units] exceeds maximum of [max] [units]".
 - ii. The Save button shows "Invalid Test Point!" or "Missing Fields!" The button color changes to red temporarily.
 - iii. To resolve: Fix the issue and try saving again.

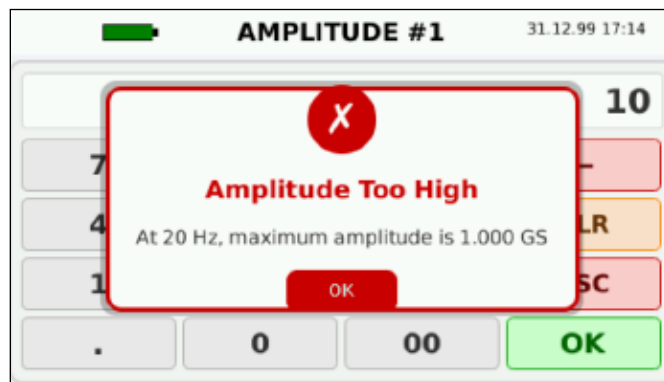

Figure 35



Figure 36

- b. If validation is successful:
 - i. The configuration will be saved to the onboard SQL database.
 - ii. Successful creation is confirmed by the popup shown in *Figure 36*.
 - iii. The configuration is now available for sensor testing.

Reports Screen

At completion of a test, the test data is automatically saved in the onboard memory and can be recalled and exported to the USB flash drive at any time. On the Test Review screen, saved certification test records can be exported individually as PDF or CSV files, all test records can be exported as CSV files, and test records can be deleted.

1. Connect a USB flash drive to the AT-2040.
 - a. Power off the AT-2040. **NOTE:** The shaker must be powered off to load a USB flash drive.
 - b. Insert the USB flash drive into the USB slot at the top of the shaker.
 - c. Power on the AT-2040.
2. On the main menu screen, select **Reports** to open the Test Review screen.

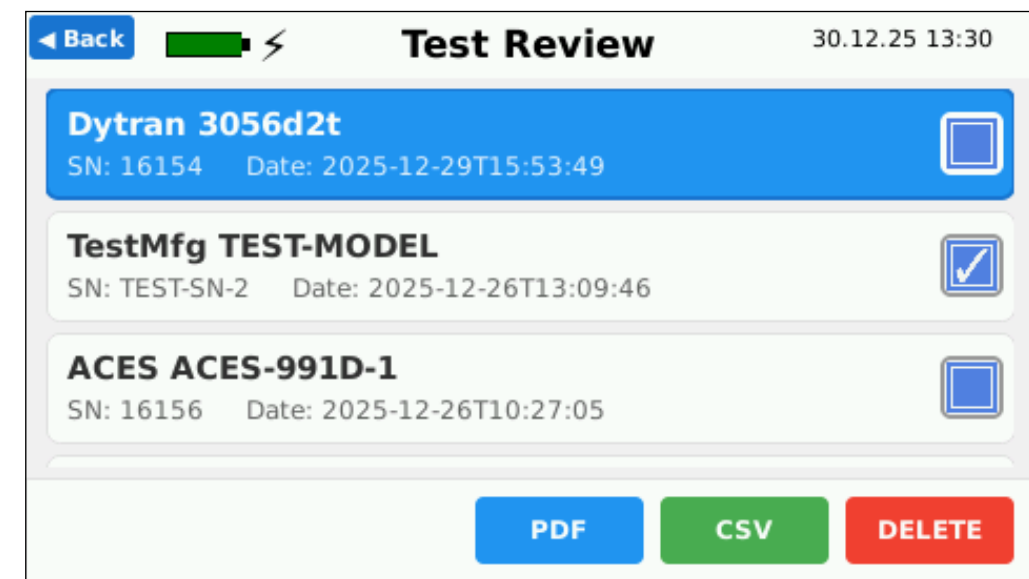
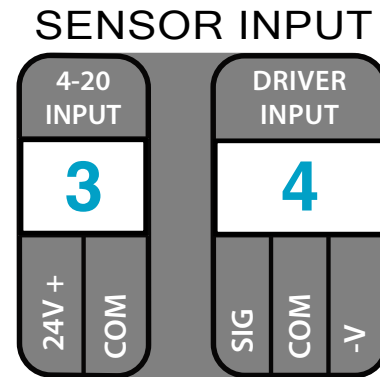

Figure 37

3. To export selected test reports to the USB flash drive as PDF or CSV files:
 - a. Select the test record(s) you want to export.
 - b. Select the **PDF button** to save the record(s) to PDF; OR
 - c. Select the **CSV button** to save the record(s) to a CSV file.
 - d. When all records have been successfully saved to the USB flash drive, the onscreen message "Save Complete" will display.
 - e. Remove the USB flash drive and review the test(s) on your computer.
4. To deleting test record(s):
 - a. Select the test record(s) you want to delete.
 - b. Select the **Delete button**.
 - c. All selected test records will be deleted from the AT-2040 onboard memory.

Calibrating sensors

1. On the main screen, select **Vibration Output** to run a manual test.
2. **For IEPE Accelerometers:**
 - a. Mount the sensor and connect it to the BNC Sensor Input connector.
 - a. Select the **Channel** button and choose **IEPE**.
3. **For Charge Accelerometers:**
 - a. Mount the sensor and connect it to the BNC Sensor Input connector.
 - b. Select the **Channel** button and choose **Charge**.
4. **For 4–20 mA Transmitters:**
 - a. Mount the sensor.
 - b. Connect the sensor to the **4–20 Input** (labeled "3" in):
 - i. Connect +24 volts to "**24V+**".
 - ii. Connect Common to "**COM**".
 - c. Select the **Channel** button and choose **4–20mA**.



NOTES:

- AT-2040 will provide +24 volts to power the sensor and read back current from the transmitter.
- When connected with no vibration, the transmitter will display 4 mA. If the transmitter is connected and the current reads 0 mA of current, the sensor is faulty or not connected.

Triaxial Sensors

Calibrating triaxial sensors is done in the same way as a uniaxial sensor, but the measurements are taken three times on three different axes.

Recommended method: Plug the sensor into the 8-pin DIN connector to change between axes using the calibrator's electronics and internal relays. Using this method, the operator only needs to change the positioning of the sensor and not the cable.

Alternate method: If the operator would prefer to use BNC breakouts instead of the internal electronics, the shaker supports that as well.

To calibrate a triaxial accelerometer:

1. Mount and connect the accelerometer.
2. On the main screen, select **Vibration Output** to run a manual test.
3. Select the **Channel** button and choose the appropriate channel.
4. Take the first set of readings for the X-axis (*Figure 38*).
5. Rotate the sensor 90 degrees (*Figure 39*) and select the next triaxial channel on the Vibration Output screen.

NOTE: If using BNC breakouts, the operator must stay on Triax Channel A and change the connector manually instead.

4. Take a second set of readings.
5. Rotate the sensor 90 degrees, select the next triaxial channel on the Vibration Output screen, and take a third set of readings (*Figure 40*).



Figure 38



Figure 39



Figure 40

Proximity Probes

Installing the Proximity Probe Kit

Description	Qty	Part No.	
Steel Target (AISI 4140)	1	PRX-102	
Proximity Probe Adapter Arm	3/8" Clamp	1	PRX-103
	1/4" Clamp	1	PRX-104
	6mm Clamp	1	PRX-105
	8mm Clamp	1	PRX-106
	10mm Clamp	1	PRX-107
Mounting Leg	1.5"	2	PRX-108
	2.0"	2	
	3.0"	2	
Proximity Probe Mounting Bar	1	PRX-109	
Micrometer with Non-Rotating Spindle	1	PRX-110	
Stainless-Steel Thumbscrew	2	PRX-111	
Panel Adapter	2	PRX-112	

Table 6 Part No. PRX-100 Proximity Probe Adapter Kit Contents



To assemble and install the proximity probe kit ():

1. Install the AISI-4140 steel target (A) by screwing it into the reference accelerometer.
2. Install the two panel adapters (B) into the screw locations labeled "PROX" on the front panel.
3. Insert the micrometer (C) through the large central hole in the proximity probe mounting bar (D).
4. Loosely tighten the set screw (E) on the rear of the mounting bar to hold the micrometer in place.
5. Find the correct size proximity probe adapter arm (F) and attach it to the end of the micrometer.
6. Loosely tighten the 8-32 set screw (G) on the rear of the adapter arm to secure it to the micrometer.
7. Insert the proximity probe (H) through the mounting bar (D) and into the adapter arm (F).
8. Tighten the clamp around the proximity probe using the 8-32 socket head screw (I) in the adapter arm.
9. Extend the micrometer about halfway and select the correct-size mounting legs (J) based on the distance from the proximity probe tip to the target:
 - a. Measure the probe or check the probe datasheet for sizing.
 - b. Once assembled, the probe must be able to contact the target and move 100 mils away from the target.
10. Screw the mounting legs (J) into the panel adapters (B).
11. Align the proximity probe assembly with the top of the mounting legs.
12. Screw the two stainless-steel thumbscrews (K) through the top of the mounting bar and into the mounting legs.

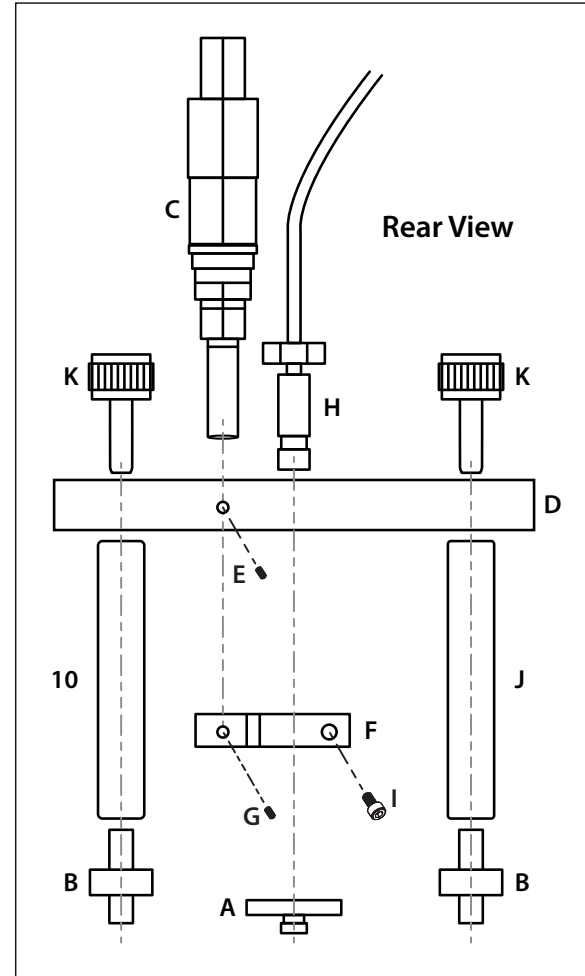

Connecting the Proximity Probe Driver

1. Connect the driver to the **Proximity Probe Driver Input** (labeled "4" in):
 - a. Connect Signal to **"SIG"**.
 - b. Connect Common to **"COM"**.
 - c. Connect -24 volts to **"-V"**.
2. On the main screen, select **Vibration Output**.
3. Select the **Channel button** and choose **Prox**.

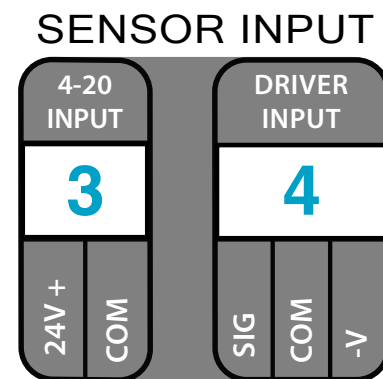

NOTE: The driver receives power from the shaker. The shaker reads in both AC and DC voltage from the driver.

Choosing Between a Dynamic and Linear Test

The shaker provides the needed -24 volts to power output for proximity probe drivers. It also reads in both AC and DC values. This allows the operator to conduct probe/driver tests without any add-on power supplies or external volt meters.

Proximity probes can be checked by conducting a dynamic or linear test:

- A dynamic (AC) test is done by reading in the AC voltage during vibration and performing a sensitivity test at a fixed-gap voltage.
- In a linear (DC) test, the gap voltage is adjusted over a linear range and the Proximity Probe Test Template spreadsheet included on the USB flash drive is completed showing the incremental scale value. A linear test can be performed with or without vibration from the shaker.

It is recommended to perform a linear test rather than a dynamic test. A linear test will show the ISF over the entire range of a probe/driver, whereas a dynamic test shows increasing amplitude (sine wave size) at a fixed-gap voltage.



Conducting a Linear Test

During a linear (DC) test, the probe is set at the 0 position and adjusted using the micrometer from 0-10-20-30, and so on, covering the entire linear range. Linear tests are done in manual mode and the amplitude is not adjusted.

To conduct a linear test:

1. Assemble and install the proximity probe kit and, per instructions in **Installing the Proximity Probe Kit** on page 53.
2. Connect the proximity probe driver. See **Connecting the Proximity Probe Driver** on page 54.
3. On the main menu screen, choose **Vibration Output** to perform a manual test.
4. Select the **Channel button**, then select **Prox**.
5. Adjust the probe to 10 mils from the target.
6. Using the Proximity Probe Test Template spreadsheet on the included USB flash drive (see **Table 7 Example Proximity Probe Test Template**), create a test over the span of 10 mil test increments. The Proximity Probe Template in Excel format is provided to assist you with these calculations.
7. Start by filling in "Test 1" data in the Excel spreadsheet at cell 6C (yellow cell in **Table 7**).
8. Rotate the spindle to 20 mils and record the voltage in cell 7C (green cell in **Table 7**).
9. Continue in 10 mil-increments until the upper-end of the linear scale, completing column C in the Excel spreadsheet ("Test 1" column in **Table 7**).
10. Calculate the voltage change by using the spreadsheet to fill in test points H6-H14 ("ISF Test 1 mV/mil" column in **Table 8**)

NOTE: It is always a good idea to perform the test a second time, completing column D in the Excel spreadsheet ("Test 2" column in **Table 7**).

11. Log and analyze data by looking for the linear relation between travel and voltage.
12. Locate the ISF and measurement tolerance printed on the proximitor and housing. For example, 200 mV over 10 mil-increments results in 2 volt (200 millivolt) changes.
13. Compare the ISF on the driver housing to the results of your test ("ISF Test 1" or "ISF Test 2" columns in *Table 8*).

NOTE: Example test data is provided in the two "EXAMPLE" columns in *Table 7* and *Table 8*.

	Test 1	Test 2	EXAMPLE
Mils	Volts	Volts	Volts
10			1.000
20			3.000
30			5.000
40			7.000
50			9.000
60			11.000
70			13.000
80			15.000
90			17.000
100			19.000

Table 7 Example Proximity Probe Test Template

Incremental Scale Factor (mV/mil)			
Mils	ISF TEST 1 (mV/mil)	ISF Test 2 (mV/mil)	EXAMPLE ISF (mV/mil)
20	0	0	200
30	0	0	200
40	0	0	200
50	0	0	200
60	0	0	200
70	0	0	200
80	0	0	200
90	0	0	200
100	0	0	200

Table 8 ISF data auto-populates based on test data

Conducting a Dynamic Test

During a dynamic (AC) test, the shaker takes on the role of simulating a rotating shaft. The 4140 steel target will produce the same vibration signals as a steel shaft. In this test, the operator will set the probe gap voltage and adjust the amplitude. With the shaker, this can be performed in either manual or automatic mode.

1. Assemble and install the proximity probe kit. See **Installing the Proximity Probe Kit** on page 53.
2. Connect the proximity probe driver. See **Connecting the Proximity Probe Driver** on page 54.
3. Determine the gap voltage:

a. **Option 1 (preferred method):**

- i. Locate the recommended gap setting on the proximity probe driver spec sheet:

Example Driver Spec Sheet (for 200 mV/mil probe/driver combination)

Recommended Gap Setting	1.27mm (50 mils)
-------------------------	------------------

- ii. Determine the exact voltage at the center of the linear range, using the recommended gap setting and the following formula:²

(recomm. gap setting in mils*0.2)-1 = volts DC [(50*0.2)-1 = -9 volts]

b. **Option 2 (If a recommended gap setting is not available):**

- i. Locate the linear range listed on the driver spec sheet (most probe and driver combinations are 200 mV/mil, where every 10 mils is equal to 2 volts):

Example Driver Spec Sheet (for a 200 mV/mil probe/driver combination)

Linear Range	2 mm (80 mils). Linear range begins at approximately 0.25 mm (10 mils) from the target and is from 0.25 to 2.3 mm (10 to 90 mils) (approximately -1 to -17 Vdc).
--------------	--

- ii. Determine the exact voltage at the center of the linear range, using the following formula:²

((range/2+10)*0.2)-1 = volts DC [((80/2+10)*0.2)-1 = -9 volts]

NOTE: Always remember that the linear range does not begin until the probe is 10 mils from the target.

4. Set the micrometer to the correct gap voltage:
 - a. The gap voltage is the DC voltage measurement from the probe/driver and is shown as a negative value.
 - b. Rotate the micrometer clockwise to push the probe all the way down until it contacts the steel target.

NOTE: The GAP V (DC voltage value) on your calibrator should read less than -1 volt.

- c. Rotate the micrometer counterclockwise to retract the probe tip until the GAP V reads the previously calculated value. In our example, we determined a gap voltage of -9 volts.

² Both formulas will equate the voltage at the center of the linear range. In both examples shown above, our result is -9 volts DC.

5. Run a manual test or an auto test.

To perform a manual test:

1. On the main menu screen, choose **Vibration Output** ().
2. Select the **Channel** button, then select **Prox** (Figure 41).
3. Select the **Start** button to begin the manual sensor test.
4. Adjust the speed to the same RPM as the driveshaft you would like to simulate. Then, increase the amplitude over a range of 1 to 10 mils. (Figure 42)

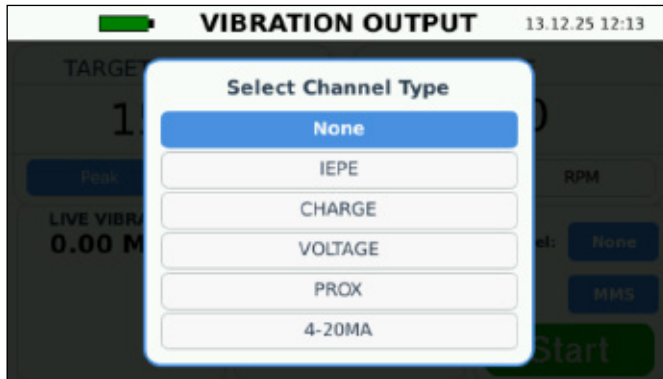
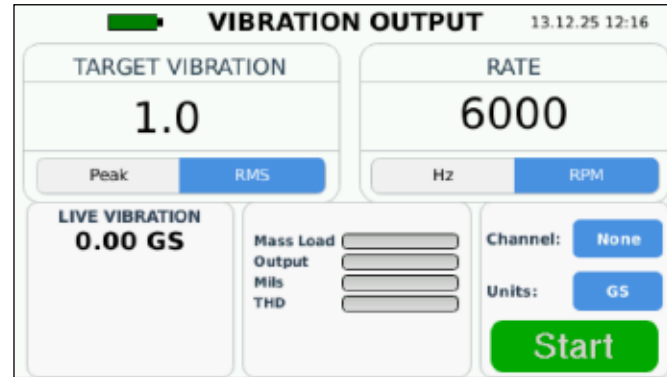

Figure 41



Figure 42

To perform an auto test:

1. On the Settings screen, select **Test Setup** to open the Test Setup screen.
2. Add a custom proximity probe sensor if needed (). See detailed instructions in **Test Setup Screen** on page 45.
3. On the main home screen, choose **Sensor Test**.
4. Then select the manufacturer (Figure 43) and the sensor (Figure 44) to run an auto test.

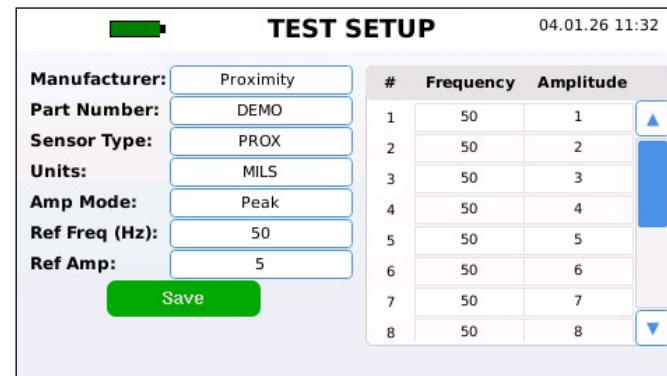

5. Select the **Start** button to begin the auto test. Select the **Table/Graph** button to toggle between graph view (Figure 45) and table view (Figure 46).
6. During the auto test, the shaker will conduct the test without the need for further adjustments.

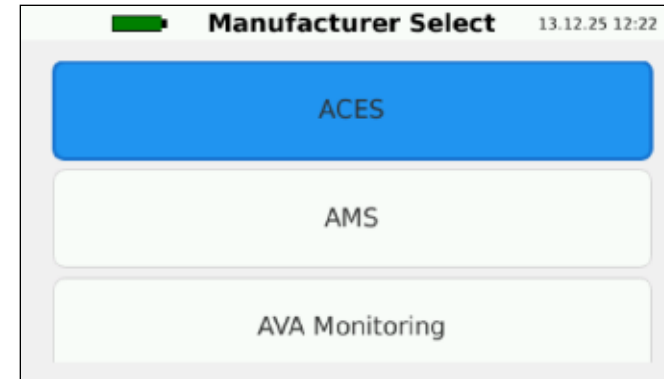

Figure 43

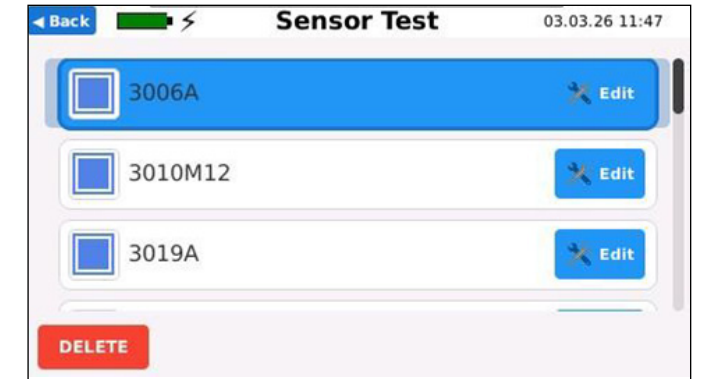

Figure 44

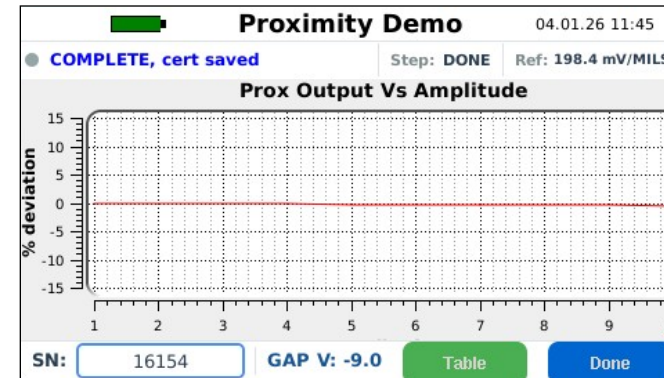

Figure 45

Frequency	Amplitude	Sensitivity	Deviation%	Phase°
50	3.0	198.2	-0.1	
50	4.0	198.0	-0.2	
50	5.0	197.9	-0.3	
50	6.0	197.8	-0.3	
50	7.0	197.7	-0.4	
50	8.0	197.6	-0.4	
50	9.0	197.5	-0.5	
50	10.0	197.4	-0.5	

Figure 46

MEMS-100 adapter board (optional accessory)

The MEMS adapter board allows an AT-2040 to be used with components such as PR and capacitive sensors manufactured by Kistler®, Endevco®, and Dytran®. The adapter plugs into the shaker DIN 8 connector for power and signal. 7 to 10 volt power is supplied to the sensor, and the adapter board converts the signal from a differential input to a single-ended for sensitivity measurement. The adapter can also be used with 3-wire capacitive sensors by a simple DIP Switch Toggle. See the MEMS-100 adapter board diagram in *Figure 47*.

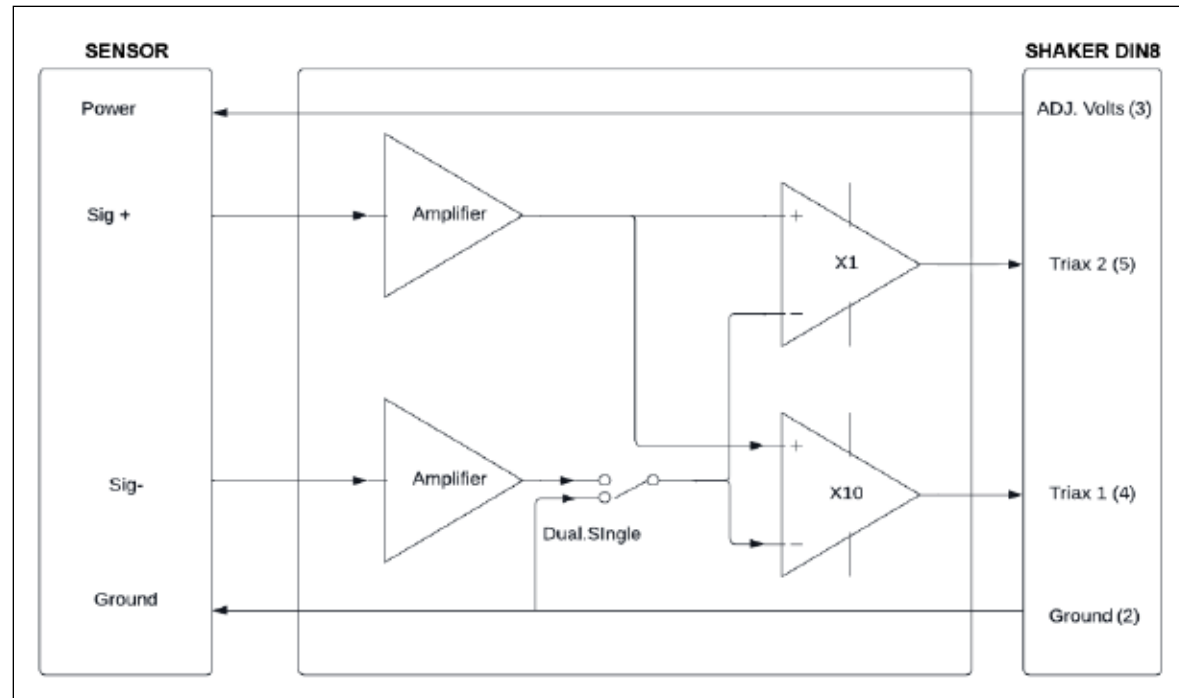

Figure 47

MEMS-100 Specifications		
Programmable Supply Voltage	Min 7	Max 20
X1 (For High Sensitivity 500 to 2000 mv/G Sensors)	Gain 10.0 ±0.01% Common mode 0–20 V Common mode rejection 80 dB	
X10 (For 0.1mv to 500 mv/G Sensors)	Gain 1.0 ±0.025% Common mode ±0–11 V Common mode rejection 80 dB	

Figure 48

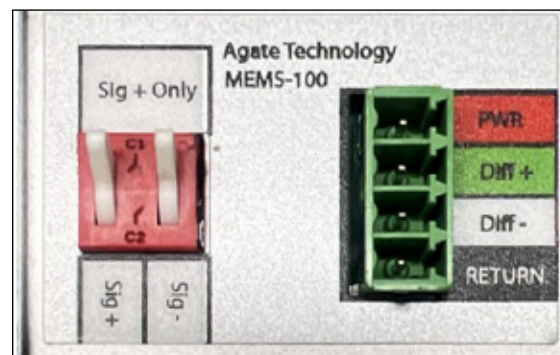

Figure 49

Controlling the shaker remotely

The shaker can be controlled remotely using a wireless-connected or Ethernet-connected computer and VNC Viewer or controlled through a standard TCP/IP connection.

Controlling the AT-2040 Via VNC Viewer

Installing and Setting Up the VNC Viewer

1. Set up the wireless connection (optional step):

NOTE: Skip to the next step if you are using a hard-wired Ethernet connection.

- a. On the Settings screen, select **Network**.
- b. Enter the identifying name of the wireless network in the **ESSID input** (*Figure 50*).
- c. Enter the wireless network password in the **Password input**.
- d. Plug a wireless network adapter into one of the USB ports and restart the shaker.



Figure 50

2. Click to download and install the [VNC Viewer](#) from VNC Connect/Real VNC.
3. Start the VNC Viewer.
4. Select **File > New Connection** from the VNC Viewer menu.
5. Locate the shaker's IP address ("Wired" or "Wireless" depending on your setup) on the Network Settings screen (*Figure 51*).

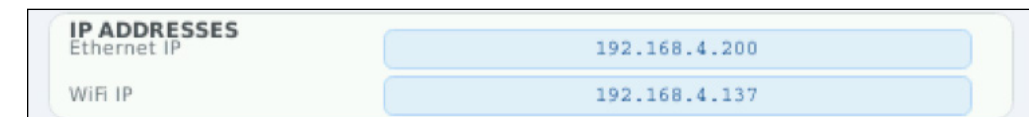

Figure 51

- Enter the shaker's IP address in the **VNC Server input** to complete the login setup (Figure 52).

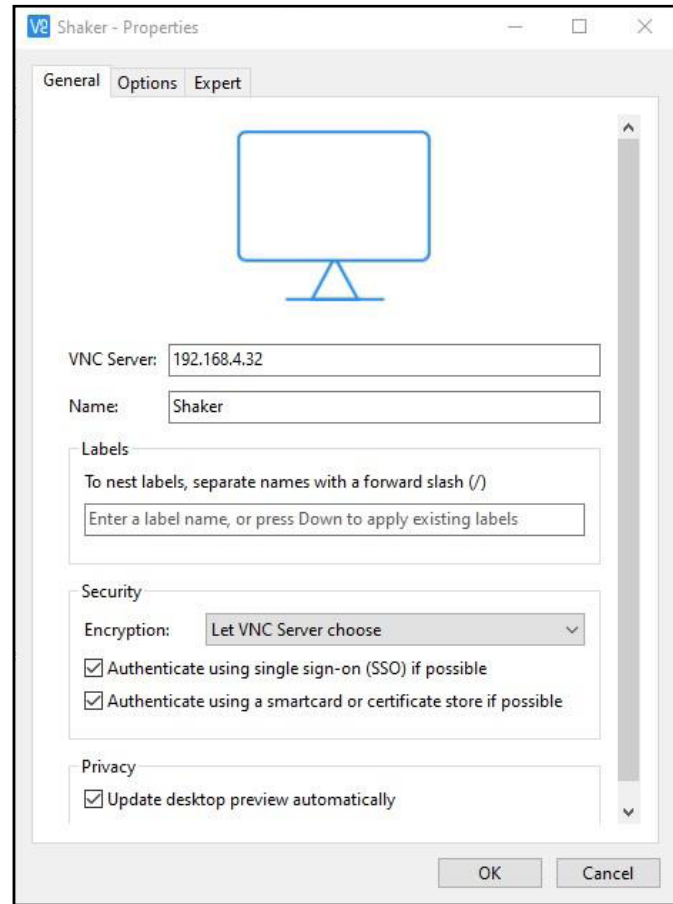

Figure 52

- Optional: Enter an identifying name in the **Name input**, such as "AT-2040" or "Shaker."
NOTE: There is no login or password required for the VNC Viewer setup.
- VNC Viewer is now connected, and the shaker is available to be controlled on a remote computer.
- Right-click on the thumbnail for the shaker and choose **Connect** to open a remote connection to the shaker.

Controlling the AT-2040 Via TCP Command Protocol

Overview

The AT-2040 Portable Vibration Calibrator provides a lightweight remote-control interface that allows external systems, automation scripts, and software tools to operate the calibrator through a standard TCP/IP connection. This interface mirrors the primary functions available on the instrument's touchscreen, enabling remote test execution, status monitoring, sensor selection, and data export.

NOTE: This section describes the supported customer-facing command set, connection details, and example usage. Administrative, factory, and service-only commands are intentionally excluded from this section.

Connection Details

The AT-2040 exposes a remote interface over TCP/IP.

Parameter	Value
Default Port	2000/TCP
Protocol	Plain-text commands
Response Format	Text status responses or data values
Connection Method	Any TCP client (e.g., nc, Python socket, LabVIEW, etc.)

Example Connection: nc 192.168.4.108 2000

Command Structure

Commands consist of a single ASCII keyword, optionally followed by arguments. Responses typically return:

- OK
- A value (e.g., frequency, acceleration, status)
- A formatted data block (CSV or PDF exports)

NOTE: Commands are case-insensitive.

Command Reference (User-Accessible Commands Only)

Basic System Commands

Command	Description
hello	Confirms connectivity. Device responds "Hi There!".
help	Displays a list of available remote commands.
version	Returns the current software version installed on the instrument.

Test Operation Commands

These commands mirror the touchscreen control functions for starting, pausing, and managing tests.

Command	Description
run	Begin the currently configured test.
stop	Stop the running test.
pause	Pause an active test.
resume	Resume a paused test.
hold	Enable hold mode. Autotest will pause at each step.
release	Advance to the next step when hold is enabled.
nohold	Disable hold mode; autotest proceeds continuously.

Navigation Commands

These commands allow automated control of screen navigation on the AT-2040.

Command	Description
gotosetup	Navigate to the Setup screen.
gotomain	Navigate to the Main screen.
gototest	Navigate to the Test screen.
gotomanual	Navigate to Manual Calibration mode.

Sensor Selection

Command	Description
sensor <model>	Select a sensor model from the database.
serial <number>	Assign or modify the sensor serial number.

Example:

- sensor 352C33
- serial 12345

Test Type Selection

Command	Description
autotest	Configure Autotest mode.
sbs	Configure Side-by-Side comparison mode.
mancal	Configure Manual Calibration mode.
autocal	Configure Automated Calibration mode.

Status & Measurement Queries

These commands retrieve real-time information from the test in progress.

Command	Description
status	Returns overall test status.
state	Returns system state (Idle, Running, Paused, etc.).
getsensitivity	Current measured sensitivity.
getfrequency	Current output frequency.
getacceleration	Current output acceleration.
getreference	Current reference accelerometer reading.
gettest	Current test-sensor reading.
gresult	Returns the final test result object.

Data Export Commands

These commands retrieve stored results from the instrument.

Command	Description
results	Returns processed results for the active or completed test.
getcsv	Exports results in CSV format.
getpdf	Exports the calibration report in PDF format.

Test Configuration Commands

These commands adjust test conditions such as frequency, acceleration, and units.

Command	Description
setfrequency <value>	Set the test frequency in Hz.
setacceleration <value>	Set the target acceleration amplitude.
units <unit>	Set vibration units (e.g., GS, MSS, IPS).

Example:

- setfrequency 1000
- setacceleration 1.0
- units GS

Channel Selection

These commands are used when calibrating multi-channel sensors or switching between measurement paths.

Command	Description
channel <n>	Select channel number n.
setchannel <n>	Set active measurement channel.

Remote Autotest Step Control

These commands support automated systems that integrate the AT-2040 into scripted calibration routines.

Command	Description
remotehold <0 1>	Enable/disable step-by-step control of autotest.
remotehold?	Query hold status.
nextstep	Advance to the next test point (when hold is active).
stepstatus?	Returns step status (WAITING, RUNNING, STEP_COMPLETE, TEST_COMPLETE, IDLE).

Additional Remote Engine Control (High-Level GUI-Equivalent Commands)

These commands correspond directly to user-accessible controls on the AT-2040 interface and do not expose internal hardware functions.

Command	Description
frequency <value>	Set output frequency (Hz).
frequency?	Query set frequency.
amplitude <value>	Set target amplitude.
amplitude?	Query measured amplitude.
targetamp?	Query target amplitude setting.
units <unit>	Set vibration units.
units?	Query vibration units.
distortion?	Return harmonic distortion measurement.
start	Start shaker output.
stop	Stop shaker output.
state	Query engine state.
model	Returns device model information.
getdata	Returns combined data set (e.g., acceleration, distortion, output percentage).

Example Automation Sequence

To run a remote autotest, enter the commands for each step:

1. Connect to the device:
 - a. nc 192.168.4.108 2000
2. Choose the sensor:
 - a. sensor 352C33
 - b. serial 12345
3. Configure the test:
 - a. autotest
 - b. setfrequency 100
 - c. setacceleration 1.0
 - d. units GS
4. Begin the test:
 - a. run
5. Check progress:
 - a. status
 - b. getsensitivity
6. Retrieve results:
 - a. getcsv
 - b. getpdf

Notes and Best Practices

- Commands use plain text; avoid sending binary data.
- Some commands require a valid test mode to be selected.
- Test results should always be retrieved after the test completes to ensure accuracy.
- When integrating with automation, wait for the instrument to respond before sending the next command.

AT-2040 Remote Command Quick Reference

Connection

Function	Command	Notes
Test connection	hello	Returns "Hi There!"
Help list	help	Displays supported commands
Software version	version	Returns application version

Test Control

Function	Command	Notes
Start test	run	Begins configured test
Stop test	stop	Ends test immediately
Pause	pause	Pauses running test
Resume	resume	Resumes paused test
Enable step hold	hold	Autotest pauses each step
Advance when held	release	Moves to next step
Disable hold	nohold	Autotest runs continuously

Navigation

Function	Command	Notes
Go to Setup screen	gotosetup	
Go to Main screen	gotomain	
Go to Test screen	gototest	
Manual calibration screen	gotomanual	

Sensor Selection

Function	Command	Notes
Set sensor model	sensor <model>	sensor 352C33
Set serial number	serial <number>	serial 12345

Test Type Selection

Mode	Command	Notes
Autotest Mode	autotest	/
Side-by-Side Mode	sbs	/
Manual Calibration Mode	mancal	/
Auto Calibration Mode	autocal	/

Status & Measurement

Query	Command	Returns
System status	status	Running, Idle, Paused, etc.
System state	state	Current state code
Sensitivity	getsensitivity	mV/g, pC/g, etc.
Frequency	getfrequency	Hz
Acceleration	getacceleration	g or selected units
Reference reading	getreference	Reference channel
Test sensor reading	gettest	DUT channel
Test result	gresult	Final result object

Data Export

Function	Command	Output
Test results	results	Text result block
Export CSV	getcsv	CSV output
Export PDF	getpdf	PDF calibration report

Test Configuration

Function	Command	Example
Set frequency	setfrequency <Hz>	setfrequency 1000
Set acceleration	setacceleration <g>	setacceleration 1.0
Set units	units <unit>	units GS (Supported units include: GS, MSS, IPS, MMS, MILS, MM, UM)

Channel Control

Function	Command	
Select channel	channel <n>	
Set active channel	setchannel <n>	

Autotest Step Control

Function	Command	Notes
Enable/disable remote hold	REMOTEHOLD <0	
Query hold status	REMOTEHOLD?	
Advance to next point	NEXTSTEP	
Query step status	STEPSTATUS?	Status values: WAITING, RUNNING, STEP_COMPLETE, TEST_COMPLETE, IDLE

High-Level Output Control (GUI-Equivalent)

Function	Command	Notes
Set output frequency	FREQUENCY <Hz>	
Query frequency	FREQUENCY?	
Set amplitude	AMPLITUDE <value>	
Query amplitude	AMPLITUDE?	
Query target amplitude	TARGETAMP?	
Set vibration units	UNITS <unit>	
Query units	UNITS?	
Query harmonic distortion	DISTORTION?	
Start shaker	START	
Stop shaker	STOP	
Query engine state	STATE	
Device model	MODEL	
Combined data block	GETDATA	

Product maintenance

Shaker Recalibration

Recalibration is recommended once per year.

Battery

Battery life averages five years. We will replace the battery for free, as needed, during recalibration. The battery can only be replaced at the Agate Technology factory. Third-party attempts to replace the battery will void the two-year limited warranty.

Service Notes

Service Performed:	<input type="checkbox"/> Recalibration	<input type="checkbox"/> Battery Replaced	Date: _____
Service Performed:	<input type="checkbox"/> Recalibration	<input type="checkbox"/> Battery Replaced	Date: _____
Service Performed:	<input type="checkbox"/> Recalibration	<input type="checkbox"/> Battery Replaced	Date: _____
Service Performed:	<input type="checkbox"/> Recalibration	<input type="checkbox"/> Battery Replaced	Date: _____
Service Performed:	<input type="checkbox"/> Recalibration	<input type="checkbox"/> Battery Replaced	Date: _____
Service Performed:	<input type="checkbox"/> Recalibration	<input type="checkbox"/> Battery Replaced	Date: _____

Operator notes

A2LA accreditation



Figure 53 AL2A Accredited Laboratory Certification for Agate Technology

Appendix A

Test Point Validation

Frequency Validation

- **Valid Range:** 10 to 10,000 Hz. **NOTE:** Frequency is validated separately from amplitude.
- **Errors:**
 - **Error Conditions:** If you enter a value below 10 Hz or above 10,000 Hz, the system will show the error message: "Frequency must be between 10 and 10,000 Hz."
 - **Actions:** Invalid frequency is NOT saved. Correct the value and try again.

Amplitude Validation

- Amplitude validation depends on the frequency and selected units.
- **Minimum Amplitude:** All test points must have an amplitude of at least **0.5 g** (or equivalent in other units), regardless of frequency. Minimum amplitude equivalents at 100 Hz:
 - **GS:** 0.500 g minimum
 - **MSS:** 4.90 m/s² (MSS) minimum
 - **IPS:** 0.307 IPS minimum
 - **MILS:** 4.900 MILS minimum
 - **MMS:** 7.810 MMS minimum
 - **MM:** 0.124 MM minimum
 - **UM:** 124.5 UM minimum
- **Errors:**
 - **Error Conditions:** If you enter a value below 0.5g (or equivalent in other units), the system will show the error message: "Amplitude must be at least [min] [units]".
 - **Actions:** Invalid amplitude is NOT saved. Correct the value and try again.

Frequency-Dependent Amplitude Limits

The Test Setup screen enforces frequency-dependent amplitude limits based on the Labworks ET-132-203 shaker specifications. These limits ensure safe operation and prevent damage to the shaker system.

These limits work across all units: whether you're using g, IPS, mils, mm/s, or any other unit, the system automatically converts the g-based limits to the equivalent values in your selected units.

When entering amplitude values for test points, the system will validate that the amplitude does not exceed the maximum allowed for the specified frequency.

Frequency Range	Maximum Amplitude (g)
Up to 10 Hz	0.5 g
Up to 20 Hz	1.0 g
Up to 30 Hz	3.0 g
Up to 40 Hz	5.0 g
Up to 100 Hz	10.0 g
Up to 500 Hz	10.0 g
Up to 3000 Hz	5.0 g
Up to 4000 Hz	2.0 g
Up to 6000 Hz	1.0 g
Up to 8000 Hz	0.5 g
Up to 10000 Hz	1.0 g

Table 9 Frequency-Dependent Amplitude Limits (in g 0-Peak)

NOTE: The system automatically converts these limits to your selected units.

Automatic Unit Conversion

The system supports the following units and automatically converts the g-based limits:

- **GS:** Acceleration in g (gravity units)
- **MSS:** Acceleration in m/s²
- **IPS:** Velocity in inches per second
- **MMS:** Velocity in mm/s
- **MILS:** Displacement in mils (thousandths of an inch)
- **MM:** Displacement in millimeters
- **UM:** Displacement in micrometers

Example conversions at 100 Hz:

- 10.0 g = 96.67 m/s² (MSS)
- 10.0 g = 6.15 IPS (inches/second)
- 10.0 g = 156.2 MMS (mm/s)
- 10.0 g = 98.0 MILS (peak-to-peak displacement)
- 10.0 g = 2.49 MM (peak-to-peak displacement)
- 10.0 g = 2489 UM (peak-to-peak displacement)

Quick Reference: Limits in Common Units

This table shows maximum amplitude limits at key frequencies for the most commonly used units:

Frequency	GS (g)	IPS	MILS (p-p)	MMS	MSS (m/s ²)
10 Hz	0.5	3.07	490.0	78.1	4.90
20 Hz	1.0	3.07	245.0	78.1	9.81
30 Hz	3.0	6.15	326.7	156.2	29.42
50 Hz	5.0	6.15	196.0	156.2	49.03
100 Hz	10.0	6.15	98.0	156.2	98.07
500 Hz	10.0	1.23	3.92	31.2	98.07
1000 Hz	5.0	0.31	0.49	7.81	49.03
3000 Hz	5.0	0.10	0.05	2.60	49.03
5000 Hz	1.0	0.01	0.004	0.31	9.81
8000 Hz	0.5	0.004	0.001	0.10	4.90
10000 Hz	1.0	0.006	0.002	0.16	9.81

Table 10 Maximum Amplitude Limits in Common Units

NOTES:

- MILS values are peak-to-peak (p-p) displacement.
- All other values are 0-Peak.
- Values rounded for readability.
- Use these as a quick reference when planning test points.

ERROR EXAMPLES

- "At 5000 Hz, maximum amplitude is 1.000 GS"
- "At 100 Hz, maximum amplitude is 6.148 IPS"
- "At 8000 Hz, maximum amplitude is 0.500 GS"
- Invalid amplitude is NOT saved. Reduce amplitude and save again.

Unit Selection

- **Choose Appropriate Units:** Select units that match your test requirements and sensor specifications.
- **Understand Conversions:** The system automatically converts limits to your selected units
- **Change Units Anytime:** You can change units at any time; the validation limits will automatically adjust.
- **Displacement Units:** When using displacement units (MILS, MM, UM), remember these are frequency-dependent:
 - Higher frequencies = smaller displacement for the same acceleration.
 - Lower frequencies = larger displacement for the same acceleration.

Validation Workflow / How Validation Works

1. **Enter Frequency First:** When creating a test point, always enter the frequency value before the amplitude
2. **Enter Amplitude:** When you tap the amplitude input and enter a value, the system will:
 - a. Check the frequency for that test point.
 - b. Determine the maximum allowed amplitude based on the frequency.
 - c. Validate your entered amplitude against this maximum.
 - d. Display an error if the amplitude exceeds the limit.
3. If validation fails, review error messages and adjust the amplitude to be within the allowed limit.
4. Continue to the next test point.

Amplitude and Frequency Changes and Validation

IMPORTANT: If a frequency and amplitude pair is set (for example, 100 Hz at 10 g) and the frequency is then changed to a lower value (such as 50 Hz), an error will occur if the previously set amplitude exceeds the allowable limit at the new frequency.

Example Scenario:

1. You set: 100 Hz, 10.0 g (valid).
2. You change the frequency to: 5000 Hz.
3. System checks: Is 10.0 g valid at 5000 Hz?
4. At 5000 Hz, max is 1.0 g.
5. Error: "Amplitude Invalid for New Frequency: At 5000 Hz, amplitude 10.0 GS exceeds maximum of 1.000 GS. Please adjust amplitude."
6. Frequency is restored to 100 Hz.
7. You must reduce amplitude FIRST, then change frequency.

Validation Examples

Example 1: Valid Entry (g units)

- **Units:** GS
- **Frequency:** 100 Hz
- **Maximum allowed amplitude:** 10.0 g
- **User enters:** 8.5 g
- **Result:** Accepted (8.5 g is less than 10.0 g maximum)

Example 2: Invalid Entry (g units)

- **Units:** GS
- **Frequency:** 5000 Hz
- **Maximum allowed amplitude:** 1.0 g
- **User enters:** 3.0 g
- **Result:** Error displayed: "At 5000 Hz, maximum amplitude is 1.000 GS"

Example 3: High Frequency Limit (g units)

- **Units:** GS
- **Frequency:** 7500 Hz
- **Maximum allowed amplitude:** 0.5 g
- **User enters:** 0.5 g
- **Result:** Accepted (exactly at the maximum limit)

Example 4: Low Frequency (g units)

- **Units:** GS
- **Frequency:** 15 Hz
- **Maximum allowed amplitude:** 1.0 g
- **User enters:** 2.0 g
- **Result:** Error displayed: "At 15 Hz, maximum amplitude is 1.000 GS"

Example 5: Valid Entry (IPS units)

- **Units:** IPS (inches per second)
- **Frequency:** 100 Hz
- **Maximum allowed amplitude:** 10.0 g = 6.15 IPS
- **User enters:** 5.0 IPS
- **Result:** Accepted (5.0 IPS is less than 6.15 IPS maximum)

Example 6: Invalid Entry (IPS units)

- **Units:** IPS
- **Frequency:** 100 Hz
- **Maximum allowed amplitude:** 10.0 g = 6.15 IPS
- **User enters:** 8.0 IPS
- **Result:** Error displayed: "At 100 Hz, maximum amplitude is 6.148 IPS"

Example 7: Valid Entry (MILS units)

- **Units:** MILS (peak-to-peak displacement)
- **Frequency:** 100 Hz
- **Maximum allowed amplitude:** 10.0 g = 98.0 MILS
- **User enters:** 85.0 MILS
- **Result:** Accepted (85.0 MILS is less than 98.0 MILS maximum)

Example 8: Invalid Entry (MMS units)

- **Units:** MMS (mm/s)
- **Frequency:** 5000 Hz
- **Maximum allowed amplitude:** 1.0 g = 31.24 MMS
- **User enters:** 50.0 MMS
- **Result:** Error displayed: "At 5000 Hz, maximum amplitude is 31.240 MMS"

Common Scenarios*Scenario 1: Wide Frequency Sweep*

- If testing from 10 Hz to 10,000 Hz, plan amplitude values carefully
- Low frequencies (10-40 Hz): Limited to 0.5-5.0 g (or equivalent in other units)
- Mid frequencies (100-500 Hz): Can use up to 10.0 g (or equivalent)
- High frequencies (3000+ Hz): Drop back down to 0.5-2.0 g (or equivalent)
- Example in IPS at 100 Hz: Can use up to 6.15 IPS
- Example in MILS at 100 Hz: Can use up to 98.0 MILS (peak-to-peak)

Scenario 2: Resonance Testing

- When searching for resonance peaks, be aware of frequency-dependent limits
- If resonance is found at high frequency, amplitude must be reduced
- Limits apply regardless of which units you're using

Scenario 3: Sensor Comparison Tests

- When comparing multiple sensors at the same test points
- Ensure all test points respect the amplitude limits
- Consider using a consistent amplitude across frequencies where possible
- Example: 0.5 g works at all frequencies (or equivalent: 30.74 MMS at 100 Hz, 6.13 MMS at 500 Hz)

Scenario 4: Working with Different Units

- You can configure test points in GS, then switch to IPS to see equivalent values
- The system maintains the same physical vibration level
- Limits automatically convert when you change units
- Example: 5.0 g at 100 Hz = 3.07 IPS = 49.0 MILS

Error Messages Reference

Field Validation Errors

"Frequency must be between 10 and 10,000 Hz"

- **Cause:** Entered frequency is outside valid range
- **Fix:** Enter frequency between 10 and 10,000 Hz
- **Example:** Change 5 Hz to 10 Hz, or 15000 Hz to 10000 Hz

"Amplitude must be at least [min] [units]"

- **Cause:** Entered amplitude is below minimum (0.5 g equivalent)
- **Fix:** Increase amplitude to meet minimum
- **Example:** At 100 Hz in GS, enter at least 0.500

"At [freq] Hz, maximum amplitude is [max] [units]"

- **Cause:** Entered amplitude exceeds shaker limit for that frequency
- **Fix:** Reduce amplitude to or below the stated maximum
- **Example:** At 5000 Hz, reduce 3.0 g to 1.0 g or less

"Voltage must be between 2 and 23 V"

- **Cause:** Voltage Out is outside valid range
- **Fix:** Enter voltage between 2.0 and 23.0 V
- **Example:** Change 1.5 V to 5.0 V, or 30 V to 24 V

"Current must be between 2 and 8 mA"

- **Cause:** IEPE current is outside valid range
- **Fix:** Enter current between 2.0 and 8.0 mA
- **Example:** Change 1.0 mA to 2.0 mA, or 10 mA to 8.0 mA

Frequency Change Errors

"Amplitude Invalid for New Frequency"

- **Full Message:** "At [freq] Hz, amplitude [amp] [units] exceeds maximum of [max] [units]. Please adjust amplitude."
- **Cause:** You changed frequency and existing amplitude is now too high
- **What Happens:** Old frequency is restored automatically
- **Fix:**
 - First reduce amplitude first
 - Then change frequency

- **Example:**
 - Had: 100 Hz, 10.0 g
 - Tried to change to: 5000 Hz
 - System restored to: 100 Hz
 - You must: Change amplitude to ≤ 1.0 g, THEN change frequency to 5000 Hz

Save Errors

"Please enter Manufacturer and Part Number"

- **Cause:** Required fields are empty
- **Fix:** Enter both Manufacturer and Part Number
- **Example:** Enter "PCB" for manufacturer and "352C33" for part number

"Row [N]: At [freq] Hz, amplitude [amp] [units] exceeds maximum of [max] [units]"

- **Cause:** Test point in row N has invalid amplitude
- **Fix:** Edit that specific row to reduce amplitude
- **Example:** "Row 3: At 5000 Hz, amplitude 3.0 GS exceeds maximum of 1.000 GS"
 - Go to row 3
 - Change 3.0 g to 1.0 g or less
 - Try saving again

Troubleshooting Problems Creating a Custom Sensor

Problem	Causes	Solution / Examples
"Can't Save - Invalid Test Point!"		
Save button shows error.	1. One or more test points have amplitude exceeding limits. 2. Frequency is outside 10–10,000 Hz range.	1. Review error message for specific row number. 2. Navigate to that row in the table. 3. Refer to the amplitude limit table. 4. Enter an amplitude value at or below the maximum for that frequency. (If a higher amplitude is needed, consider using a lower frequency). 5. Try saving again. Example Error: "Row 5: At 8000 Hz, amplitude 2.0 GS exceeds maximum of 0.500 GS" Steps to Resolve: 1. Go to row 5. 2. Change amplitude from 2.0 to 0.5 or less. 3. Save again.
"Amplitude Invalid for New Frequency" Error		
Can't change frequency because amplitude is too high.	Existing amplitude exceeds limit for new frequency.	1. Note the error message showing max amplitude. 2. Select ESC to close number pad (frequency restored). 3. Select the amplitude field. 4. Reduce the amplitude to or below the maximum. 5. Try saving again. 6. When successfully saved, change the frequency. Example: • Current: 100 Hz, 10.0 g • Want: 5000 Hz, 10.0 g Steps to Resolve: 1. Try to change frequency to 5000 Hz → Error. 2. Select ESC to cancel. 3. Change amplitude to 1.0 g. 4. Change frequency to 5000 Hz → Success.
Need Higher Amplitude than Allowed		
Cannot enter an amplitude value.	Value exceeds amplitude limit.	Example: Test specification requires amplitude higher than the shaker limit. Solution 1. Verify the test specification is appropriate for the ET-132-203 shaker. 2. Consider using a different shaker with higher force rating. 3. Modify test specification to use amplitudes within safe limits. 4. Contact engineering team for guidance on test requirements.
Frequency Changed After Amplitude Entry		
Changed frequency, no amplitude is invalid.	When you change a frequency value, the amplitude is NOT automatically re-validated.	Solution 1. Before running the test, the save function will validate all test points. 2. If a frequency change makes an amplitude invalid, you'll see an error when saving. 3. Go back and adjust the amplitude to match the new frequency limit.
Cancel Button Doesn't Work		
Pressed ESC but original value didn't restore.	This was a bug in earlier versions. But is now fixed; ESC properly restores original value.	If the Cancel Button Still Doesn't Work 1. Close and reopen Test Setup screen. 2. Check firmware version (should be v53+). 3. Contact support if problem persists.

Test Points Scroll Off Screen		
Can't see all 15 rows.	A maximum of 8 rows appears on the screen.	Use scroll arrows on right side of table to navigate: • Tap ▲ to scroll up. • Tap ▼ to scroll down. • Each tap scrolls 2 rows.
Units Changed, Values Look Wrong		
Switched units and numbers changed.	This is NOT a bug; it's by design.	Why Did This Happen? • Amplitude limits auto-convert to selected units. • Your test point values do NOT convert. • You entered values in one unit, switched to another. Tips: • Stay in one unit system throughout configuration. • If you must switch, manually update test point values. • Delete and re-enter test points in new units.

Technical Reference

Data Storage

Custom sensor configurations stored in sensor definitions table. The following configuration data is saved:

- Sensor manufacturer
- Sensor model or part number
- Product category
- Sensor type (e.g., IEPE, charge, voltage, proximity)
- Nominal sensitivity
- Required supply voltage
- Excitation current
- Excitation voltage
- Sensor bias voltage
- Reference calibration frequency
- Reference calibration amplitude
- Reference tolerance
- Measurement units
- Scaling factor
- Sensor serial number
- Test point list (frequency and amplitude pairs)

Validation Logic

The validation occurs when:

1. User enters an amplitude value using the number pad.
2. User taps **OK** to confirm the entry.
3. System retrieves the frequency and current units for that test point.
4. System calls a function.
 - a. Function gets the g-based limit for the frequency.
 - b. If units are not GS, the units are converted.
5. System compares entered amplitude against maximum allowed in current units.
6. If exceeded, error dialog is displayed showing limit in current units.
7. If valid, amplitude is saved to the test point.

Field	Validation	Error Message
Manufacturer	Must not be empty	"Please enter Manufacturer and Part Number"
Part Number	Must not be empty	"Please enter Manufacturer and Part Number"
Voltage Out	2.0 to 23.0 V	"Voltage must be between 2 and 23 V"
Current	2.0 to 8.0 mA	"Current must be between 2 and 8 mA"
Frequency	10 to 10,000 Hz	"Frequency must be between 10 and 10,000 Hz"
Amplitude (min)	≥ 0.5 g equivalent	"Amplitude must be at least [min] [units]"
Amplitude (max)	Frequency-dependent (see <i>Table 9 Frequency-Dependent Amplitude Limits (in g 0-Peak)</i>)	"At [freq] Hz, maximum amplitude is [max] [units]"

Table 11 Validation Rules Summary

Amplitude Limit Conversion

The system uses the built-in unitConverter module to convert between units. The system uses these conversion factors:

- GS → multiplier: 1.0
- MSS → multiplier: 9.80665
- IPS → multiplier: 61.48 / frequency
- MMS → multiplier: 1561.56 / frequency
- MILS → multiplier: 9777.78 / (frequency²)
- MM → multiplier: 248.36 / (frequency²)
- UM → multiplier: 248360 / (frequency²)

Conversion Formula

- All limits are defined in g (0-Peak)
- When validating, the g limit is converted to target units
- Conversion accounts for:
 - Unit type (acceleration, velocity, displacement)
 - Frequency (for velocity and displacement units)
 - Scaler (0-Peak, RMS, Peak-to-Peak)

Integration Levels

- Level 0 (Acceleration): GS, MSS - Direct conversion, no frequency dependency
- Level 1 (Velocity): IPS, MMS - Divided by frequency
- Level 2 (Displacement): MILS, MM, UM - Divided by frequency²

Appendix B

Customizing the PDF Certificate Template

The AT-2040 can automatically generate a sensor calibration certificate. The calibration certificate can be customized to specific business branding and certification needs.

The customizable certificate template is a file written in HTML named **seismic_cert.html**. To customize the calibration certificate contents and layout, the operator will need to download the HTML template, edit it as needed, and upload the customized template to the shaker.

In addition to the customizable HTML file, the shaker supports uploading one image file for your company logo. The logo file, **logo.png**, can be added to the certificate template via the "logo" keywords (e.g. %logox1%, %logox2%). See **HTML Keywords** on page 85.

To customize the PDF certificate template:

1. Export the HTML template and logo image template from the shaker to the USB memory drive. See **Certificate Import/Export Screen** on page 37.
2. Customize the HTML template file:
 - a. The HTML certificate template is made up of:
 - i. **HTML tags** which provide the structure of the certificate PDF. See **HTML Tags** on page 84.
 - ii. **Keywords** which the shaker will use to populate the certificate with data. See **HTML Keywords** on page 85.
 - iii. **Static text** which may be added to the template, as needed.
 - b. HTML files are commonly edited in text editors, such as the default text edit application on your computer, Notepad ++, Atom, or Sublime Text. If you are new to HTML, we recommend using Adobe CC Dreamweaver, CoffeeCupHTML editor, or another visual HTML editor.
 - c. See the example HTML and keyword structures and example customized certificates on the following pages.
3. Save the customized HTML template file and your company logo file to the USB memory drive. See **Certificate Import/Export Screen** on page 37.
4. Import the customized HTML template file and company logo file to the shaker. See **Certificate Import/Export Screen** on page 37.

HTML Tags

HTML tags give an HTML file its structure. Below is a list of common HTML tags you might use to customize your certificate template.

Commonly-Used HTML Tags	
<table> </table>	Table
<tr> </tr>	Table Row Within a Table
<td> </td>	Table Data Cell Within a Table Row
<p> </p>	Paragraph of Text
 OR 	Bolded Text
<i> </i>	Italicized Text
<u> </u>	Underlined Text
 	Line Break
 	Non-Breaking Space

Table 12 Common HTML Tags

HTML Tips

1. Always make sure HTML tags are paired. An opening tag, such as **<table>**, must have a corresponding closing tag, **</table>**, at the end of the HTML element.
2. HTML tags nest within each other. Indenting nested HTML tags will help you keep track of the HTML structure. See *Figure 55* for an example of a simple HTML structure.
3. Use the non-breaking space tag ** ** to prevent important information from breaking across lines, for example: Agate Technology.
4. Further customize your certificate template by adding HTML style attributes. Style attributes allow you to control the color, size, weight, and alignment (center, left, right) of text, the size of margins and padding around text, and more.
5. Style attributes are:
 - a. Inserted inside an opening tag, such as: **<p>**
 - b. Started with: **"style="**
 - c. Separated by semicolons: **;**
 - d. Contained in quotation marks: **" "**
 - e. For example:

<p style="color: red; font-size: 125%; font-weight: bold; text-align: center; margin-top: 20px;">This is an example line of text styled in HTML.</p>

This is an example line of text styled in HTML.

HTML Keywords

Keywords are added to the HTML document where you would like the shaker to populate data. For example, %F1% will be populated by the shaker with the frequency of the first reading.

Below is a list of keywords, or data, that the shaker will populate as it performs an automatic test.

Keyword	Description	Other
%A1%...%A19%	Test Point Amplitudes	
%biasV%	Test Bias Voltage for IEPE Sensors, Test DC Voltage for Proximity Probes	
%company%	Company Name	
%D1%...%D19%	Test Point Deviation in Percentage Relative to Reference Frequency	
%F1%...%F19%	Test Point Frequencies	
%graph%	Smaller Graph	
%graphx2%	Larger Graph	
%logox1%	Company Logo	Size = 1x original
%logox2%	Company Logo	Size = 2x original
%logox4%	Company Logo	Size = 4x original
%logox8%	Company Logo	Size = 8x original
%manufacturer%	Sensor Manufacturer Name	
%model%	Sensor Model	
%RefFreqHz%	Reference Point Test Frequency	
%RefFreqRPM%	Reference Point Test RPM	
%refSens%	Sensitivity at Reference Frequency	
%S1%...%S19%	Test Point Sensitivities	
%sensorSerial%	Serial Number of Sensor	
%shakerserial%	Serial Number of Shaker	
%tech%	Tech Name	
%testdate%	Calibration Date	MM DD YYYY
%units%	Sensor Units	Gs, IPS, Mills, etc.
%vibunits%	Unit type changes depending on if testing Acceleration, Velocity or Displacement	Gs, IPS, Mills, etc.

Table 13 Supported HTML Keywords for AT-2040 Certification Template

COMPANY: %company%		MANUFACTURER: %manufacturer%	
MODEL: %model%		SERIAL #: %sensorSerial%	
REF SENSITIVITY: %refSens% (%units%)			
Frequency (HZ)	Amplitude (%vibunits%)	Sensitivity (%units%)	Deviation relative to %refFreqHZ% Hz
%F1%	%A1%	%S1%	%D1%
%F2%	%A2%	%S2%	%D2%
%F3%	%A3%	%S3%	%D3%
%F4%	%A4%	%S4%	%D4%
%F5%	%A5%	%S5%	%D5%
%F6%	%A6%	%S6%	%D6%
%F7%	%A7%	%S7%	%D7%
%F8%	%A8%	%S8%	%D8%
%F9%	%A9%	%S9%	%D9%
%F10%	%A10%	%S10%	%D10%
%F11%	%A11%	%S11%	%D11%
%F12%	%A12%	%S12%	%D12%
%F13%	%A13%	%S13%	%D13%
%F14%	%A14%	%S14%	%D14%
%F15%	%A15%	%S15%	%D15%
%graph%			
Calibration Tech: %tech%		Test Date: %testdate%	

Figure 54 Example HTML Keyword Structure in Table Format

```

<html>
  <table>
    <tr>
      <td>COMPANY: %company%</td>
    </tr>
    <tr>
      <td>MANUFACTURER: %manufacturer%</td><td>MODEL: %model%</td>
      <td>SERIAL #: %sensorSerial%</td>
    </tr>
    <tr>
      <td><b>Frequency</b></td><td><b>Sensitivity</b></td><td><b>Amplitude</b></td>
    </tr>
    <tr>
      <td>%F1%</td><td>%S1%</td><td>%A1%</td>
    </tr>
    <tr>
      <td>%F2%</td><td>%S2%</td><td>%A2%</td>
    </tr>
  </table>
</html>

```

Figure 55 Example Simple HTML Table Structure

COMPANY: %company%		
MANUFACTURER: %manufacturer%	MODEL: %model%	SERIAL #: %sensorSerial%
Frequency	Sensitivity	Amplitude
%F1%	%S1%	%A1%
%F2%	%S2%	%A2%

Figure 56 HTML Table Resulting from HTML Structure in Figure 55

CALIBRATION CERTIFICATE

COMPANY: Agate **MANUFACTURER:** Dytran
MODEL: 3010M12 **SERIAL#:** 16935

REF Sensitivity 9.88 (mV/g)

Frequency Hz	Amplitude (GS)	Sensitivity (mV/g)	Deviation relative to 100 Hz
20	1.0	9.77	-1.1
50	1.0	9.83	-0.4
75	1.0	9.89	0.1
100	1.0	9.88	0.0
500	1.0	9.89	0.1
1000	1.0	9.92	0.4
2000	1.0	9.94	0.6
3000	1.0	10.03	1.5
4000	1.0	10.17	2.9
5000	1.0	10.21	3.4
6000	1.0	10.34	4.7
7000	1.0	10.49	6.2
8000	1.0	10.65	7.8
9000	1.0	10.89	10.3
10000	1.0	11.16	13.0

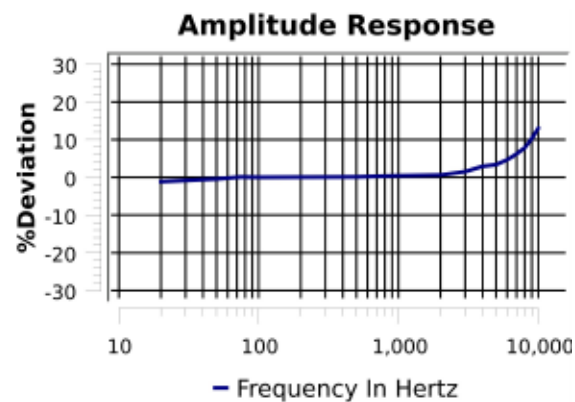

Calibration Tech: Matt **TEST DATE:** Feb 25 2022

Figure 57 Custom PDF Certificate Example



Declaration of Conformity

Application of Council Directive: 2014/35/EU

Standards to which conformity is declared: EN61010-1:2010
Manufacturer's Name: Agate Technology
Manufacturer's Address: 41743 Enterprise Circle N, 105B
 Temecula, CA 92592
Equipment Description: Vibration Sensor Test Set
Equipment Class: Class II
Model Number: AT-2040 (Inclusive of AT-2035 & AT-2030)

I, the undersigned, hereby declare that the equipment specified above conforms to the above Directive(s) and Standard(s):

Place: Temecula, California, USA
Full Name (Printed): Matthew Cornwell
Signature: *Matthew Cornwell*
Position: Product Manager



Figure 58 Custom PDF Certificate Example



Declaration of Conformity

Application of Council Directive: 2014/30/EU

Standards to which conformity is declared: EN61326-1: 2013
 EN55011 Class A Group 1
 EN61000-4-2
 EN61000-4-3
 EN61000-4-4
 EN61000-4-5
 EN61000-4-6
 EN61000-4-8
 EN61000-4-11

Manufacturer's Name: Agate Technology

Manufacturer's Address: 41743 Enterprise Circle N, 105B
 Temecula, CA 92592

Equipment Description: Vibration Sensor Test Set

Equipment Class: Electrical Equipment Measurement
 Control & Laboratory Use – Industrial

Model Number: AT-2040 (Inclusive of AT-2035 & AT-2030)

I, the undersigned, hereby declare that the equipment specified above conforms to the above Directive(s) and Standard(s):

Place: _____ Temecula, California, USA

Full Name (Printed): _____ Matthew Cornwell

Signature: _____ *Matthew Cornwell*

Position: _____ Product Manager



Figure 59 Custom PDF Certificate Example



AGATE TECHNOLOGY LLC

28936 Old Town Front St, Suite 101

Temecula, CA 92590

For the latest product news and insights, visit our website at agatetechnology.com.

For more information, call Agate Technology at (951) 719-1032
or email us at info@agatetechnology.com.

 youtube.com/agatetechnology